



**Tri-C Western Campus  
The Pantry  
C20213120  
GC BID PACKAGE  
Addendum No. 02**

To the Bidders and Plan holders of Record:

This Addendum 02 modifies and forms a part of the Bid Package dated July 16, 2021. Acknowledge receipt of this Addendum in the space provided on the Bid Form. Failure to do so shall subject the Bidder to disqualification.

1. The bid due date remains unchanged. Sealed bids will be accepted at Cuyahoga Community College District Office, 700 Carnegie Ave, until 2:00 PM on Friday, August 6. No public opening will occur.
  
2. ANSWERS TO QUESTIONS IN BID RFI 1

**ELECTRICAL**

1. Can Tri-C / Engineers supply the following:
  - Fire Alarm System provider information (reference sheet E500)
    - *Contact Chuck Hall*  
*Bay Mechanical & Electrical*  
*2221 West Park Drive Lorain, Ohio 44053*  
*(440) 282-6816*  
*See attached: Fire Alarm Design Assist Manual*
  
2. Security system provider information
  - Cable spec for Camera system, (reference sheet E200, Plan note #4)
    - Only information provided is "by Belden" *This is per the attached doc provided by the College.*
      - *See attached "camera-specs-brief" for acceptable security system suppliers and other security requirements.*
    - Where is cable to be routed to?
      - *Cable is to be routed to room G11, lower level (same level as construction, see below).*



END OF ADDENDUM NO. #2

## **SUMMARY**

Security Hardware: Furnish and install new Security Surveillance Cameras as an extension of the existing standard College Wide Amag Symmetry Completeview System .

Software and Licenses: Provide and configure system software, licenses, and enter data as required for specified operation.

Electrical Installation: The Contractor shall include all labor, services, devices and materials necessary to furnish and install a complete, functional ESS, in accordance with the Contract Documents, including but not limited to: 120VAC electrical power circuits, raceway, rough-in, wire / cable, patch cables, and jumpers.

## **PRODUCTS FURNISHED [OR] SUPPLIED BUT NOT INSTALLED UNDER THIS SECTION**

N/A

## **SUPPLIED BY OWNER.**

Network switches shall be provided by the Owner. Contractor shall provide all cabling, termination, and testing.

## **COMMISSIONING**

The Contractor shall participate in formal Commissioning of the system.

## **STANDARDS**

Unless otherwise noted, the listed standards shall define the Abbreviations, Acronyms, and Terms used in this document. Installation shall be done in accordance with best practices including but not limited to the Standards listed in this document.

### **Industry Standards**

NFPA 731, Standard for the Installation of Electronic Premises Security Systems

NEC-1, Standard for Good Workmanship in Electrical Construction

### **Owner Standards**

The following Owner Standards shall be considered as part of the bid documents. Where the Standard and this document conflict - the more stringent or costly requirement shall be required.

Physical Security Systems Design Assistance Manual (Tri-C Document, SEC-1)

Standard Cabling Installation Procedures And Guidelines (Tri-C Document, ITS Department)



## **QUALITY ASSURANCE**

The ESS shall comply with:

All pertinent codes, rules, regulations and laws of the Authority, and local jurisdiction

Requirements related to its Listings by Nationally Recognized Testing Laboratories (NRTL)

The manufacturer's printed instructions and recommendations

The requirements and intent of the specifications

All equipment shall function seamlessly with the existing College Wide ESS and match existing operations UON.

The Contractor shall provide, from the acceptable manufacturer's current product lines, equipment and components, which comply, with the requirements of these specifications. Equipment or components, which do not provide the performance and features, required by these specifications are not acceptable, regardless of manufacturer.

Prior to bidding - the Contractor, via the Supplier, shall confirm the compatibility of all existing hardware devices with the specified software and operation required by this Contract .

### **Security Equipment Suppliers**

The Supplier shall provide all equipment, technical labor, shop drawings (including completion of design documents) submittals, and warranty service.

The Security Equipment Supplier shall be one of the College's pre-approved standard security system suppliers:

- Converjnt
- US Communications
- Premise Solutions

All technicians working on site shall have a certificate of formal training by the equipment manufacturer (AMAG and Salient)

### **Security Equipment and Wiring Installers**

Contractor shall have a minimum of 5 years' experience in the installation of Electronic Security Systems of similar size and scope.

The Contractor shall provide the names and locations of at least three installations where the Contractor, has installed such systems. Indicate the type and design of each system and certify that each system has performed satisfactorily in the manner intended for a period of not less than 18 months. Submit names and phone numbers of points of contact at each site.

Installation of network cabling shall be by persons certified by BICSI for cabling installation. Equivalent certifications from other national, non-product affiliated, organizations may be acceptable. All installation of Network Cable shall be in accordance with the Owners Standards.

## **SUBMITTALS**

Product Data

Manufacturers' installation and operating Instructions

## **WARRANTY**

The Contractor shall guarantee labor, materials, and equipment provided under this contract against defects for a period of one year after the date of final acceptance of this work by the Owner and the receipt of required Closeout Documents. On-site service during the guarantee period shall be provided within 24 hours after notification. All repairs shall be completed within 48 hours after notification.

Any testing or inspection of the system by the Owner or their Representative shall not affect the Contractors obligation to provide the warranty as described.

## **PRODUCTS**

### **CAMERAS – GENERAL**

All devices must be listed as compatible by the new VMS.

All Cameras shall include:

Vandal resistant enclosure

Remote focus capability

Automatic Iris

Capability for using onboard, third party, analytics applications

Audio input or built in microphone

Minimum of 130 dB wide dynamic range.

### **Memory Card Requirements**

Each camera shall include a high speed, minimum 128GB memory card, as recommended by the camera manufacturer. If the camera does not support 128GB than provide the largest supported card.

### **Interior Camera Requirements:**

Frame Rate – Min 30 frames per second at highest resolution

Shutter Speed - 1.4s or less to 1/8,000 of a second or faster

### **INTERIOR CAMERA TYPES**

#### **SRES: Standard Resolution Requirements:**

Minimum Focal Length/FOV: 3mm-11mm

Minimum Resolution: HD 1080p

Approved Manufacturer and Model:

- XND-6080V by Hanwha Techwin
- Approved equal by Axis or Sony

**360: 360 Degree Camera Requirements:**

Minimum Focal Length/FOV: 360 Degrees

Panoramic Multi-Sensor Technology

Minimum Resolution: 2M x 4

Approved Manufacturer and Model:

- PNM-9080VQ by Hanwha Techwin
- Approved equal by Axis or Sony

**WIRE AND CABLE.**

**Data Cable:**

Basis of Design is Four (4) pairs Category 6 UTP by Belden

Terminate all conductors in Panduit MiniCom Panels and in the receptacles.

Vendor shall produce all certifications on cabling prior to installation to ensure safe installation according to TIA/EIA standards.

See the Owners Network Cabling Standards for additional information.

**EXECUTION**

**EXAMINATION**

Before submitting a proposal, the Contractor shall visit the site of work and familiarize himself with all site conditions.

**COORDINATION**

The Contractor shall initiate and ensure all required coordination has taken place.

**ITS**

Coordinate with ITS to obtain LAN addresses and settings.

**CPSS**

Coordinate with CPSS to determine requirements for all aspects of the new programming and configuration including but not limited to:

Labels

CCTV recording rates, Image quality, field of view, presets, tours, etc.

The Contractor shall initiate and ensure all required coordination has taken place.

### **OPERATIONAL REQUIREMENTS**

PRIORITIES – Unless otherwise noted the Contractor shall configure the system operation in accordance with the following priorities:

Code – Adherence to codes, laws, etc. shall take priority over all other requirements

Owner Instructions – Specific instructions resulting from coordination sessions with the Owner as documented in meeting notes

Contract Documents

Existing System Operation

Cuyahoga Community College  
Design Assistance Manual

FIRE ALARM / MASS NOTIFICATION SYSTEM





**CHANGE HISTORY AND DOCUMENT CONTROL**

Rev #	Effective Date	Changes
1.0	9/1/2016	Initial
2.0	10/1/2017	Misc Clarifications and terminology changes. Updates to EST part numbers updated.

10-9-17

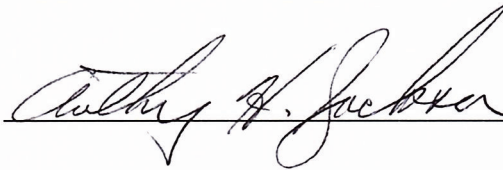
  
\_\_\_\_\_

Date:

Approved By:

---

Unless required otherwise by Ohio Law - external distribution of this document and the data contained herein shall be limited to design and security professionals for use in the design of physical security systems at Cuyahoga Community College (Tri-C). Any other use of college specific information requires the permission of Tri-C. Use of other information requires the permission of Gryffon LLC.

This document shall not be posted on publicly accessible webpages.

---





**This document / report has been prepared by:**

**Dale A. Simmons, SET, CPP, PSP**

**Gryffon LLC**

**[www.gryffon.pro](http://www.gryffon.pro)**

NICET Certified, SET # 86277

State of Ohio Board of Building Standards Certified Fire Alarm  
Designer, ID# 3229





## Table of Contents

### FRONT

Change History and Document Control .....	i
Prepared By.....	iii
Table of Contents.....	v

### 1 - INTRODUCTION

Introduction.....	1
-------------------	---

### 2 - SYSTEM OVERVIEW

SUPERVISING STATIONS.....	7
<i>Table 2.A.1. – Supervising Station Summary</i> .....	7
CONTROL UNITS.....	7
<i>Table 2.B.1 Existing Emergency Voice / Mass Notification Capabilities</i> .....	8
Master Voice Command Center (MVCC).....	8
Campus Voice Command Center (CVCC).....	9
Local Voice Command Center (LVCC).....	9
<i>Figure 2.B.5.1 – Metro Campus Existing Topology</i> .....	10
<i>Figure 2.B.5.2. – West Campus Existing Topology</i> .....	11
<i>Figure 2.B.5.3. – East Campus Existing Topology</i> .....	12

### 3 - GENERAL REQUIREMENTS

DESIGNER OF RECORD (DOR).....	15
SCOPE.....	15
CODES.....	15
STANDARDS.....	15
STANDARDS - OWNER.....	15

## Table of Contents

### 4 - EQUIPMENT REQUIREMENTS

GENERAL .....	19
FIRE ALARM CONTROL UNITS / PANELS	19
<i>Table 4.B.1 – Control Equipment Requirements.</i> .....	19
<i>Figure 4.B.1.a – New Building on An Existing Campus.</i> .....	20
PANEL SWITCHES AND INDICATORS.....	20
<i>Figure 4.C.1– LVCC-R (Annunciator).</i> .....	21
<i>Figure 4.C.2 –LVCC ( FACU) New Building / Existing Campus.</i> .....	22
APPROVED FIELD EQUIPMENT.....	23
<i>Table 4.D.1 – Required Fire Alarm Field Devices.</i> .....	23
OWNER SPECIFIC REQUIREMENTS.....	24

### 5 - COLLEGE SERVICE VENDOR

DESIGN COORDINATION.....	27
ALLOWANCES.....	27
CONTRACTOR COORDINATION REQUIREMENTS.....	27
<i>Table 5.B.1 –Scope of Allowances For Service Vendor.</i> .....	28

### APPENDIX A - EXISTING CONTROL PANEL LOCATIONS 29

### APPENDIX B - LABELING 35

### APPENDIX C- CONTACTS 37

## SECTION 1: INTRODUCTION

---





## SECTION 1 - INTRODUCTION

### A. GENERAL INFORMATION

1. Cuyahoga Community College (Tri-C) has standardized on a single Emergency Voice Fire Alarm System (EST3). By standardizing on a single, inter-operative, network of fire alarm panels the College Wide System provides additional benefit as a Mass Notification System (MNS.) Although prevalent in most college areas there are still some sites which have not been upgraded to the EST-3 system.
2. Tri-C has a service contract with a single vendor for all fire alarm systems which shall be referred to as the “College Service Vendor”. Although extensions to the system are competitively bid in accordance with state laws, the College Service Vendor must be involved to certain extents to ensure consistency is maintained.
3. The complexity of designing extensions to this system necessitated the creation of this guide to provide the following information for the designer:
  - a. Existing system locations and interconnection methods
  - b. Existing system operation and capabilities
  - c. Requirements for extensions to the system
  - d. Requirements for involvement of the existing service vendor.

### B. CAVEAT

1. This Design Assistance Manual was created to assist designers in comprehending the systems, devices, and processes normally used at Tri-C.
2. The systems at Tri-C are in a state of transition where modifications are being made to simplify operation and enhance mass notification capabilities. The information included in this document indicates the current system configuration and also the desired future configurations. It is critical that the existing conditions are verified for each project.
3. The designer of the system is fully responsible for all aspects of their design including but not limited to; verification of existing conditions, verification of current devices, or any other design task which is normally the responsibility of the designer.





## SECTION 2: SYSTEM OVERVIEW

---



## SECTION 2 - SYSTEM OVERVIEW

### A. SUPERVISING STATIONS

1. Metro Campus Police and Security Services (CPSS) Dispatch serves as a Proprietary Supervising Station for all Tri-C fire and security alarms except Corporate College East and Corporate College West.

SUPERVISING STATION STATUS	
SITE	MONITORED BY
BUC	CPSS
CCE	ADT
CCW	ADT
DIST	* ONLY 2 signals (Alarm and Trouble) received by CPSS.
EAST	CPSS
HMC	CPSS
JSTC	CPSS
METRO	CPSS
WEST	CPSS
WPSTC	CPSS
WSHCS	CPSS

Table 2.A.1. - Supervising Station Summary

### B. CONTROL UNITS

1. The College's intent is to expand emergency voice / mass notification capabilities to all new sites and to existing sites when an opportunity presents itself.

EMERGENCY VOICE / MASS NOTIFICATION CAPABILITY			
SITE	LOCAL, AT THE BLDG	FROM CAMPUS CPSS OFFICE	FROM METRO CPSS
BUC	YES	-	NO
CCE	YES	-	NO
CCW	NO	-	-
DIST	NO	-	-
EAST	YES	YES	YES
HMC	YES	-	NO
JSTC	YES	-	YES
METRO	YES	YES	YES
WEST	YES	YES	YES
WSHCS	YES	-	NO

*Table 2.B.1. – Existing Emergency Voice / Mass Notification Capabilities*

2. Master Voice Command Center (MVCC)

- a. There is only one MVCC for the entire college which is in the Metro Campus Police and Security Services office.
- b. The MVCC allows live voice instructions or preconfigured messages to be broadcast at all connected campuses.

3. Campus Voice Command Center (CVCC)

- a. Each campus requires a CVCC which is normally in the Campus Police and Security Services office. Note: The MVCC serves as the CVCC for Metro Campus.
- b. The CVCC allows live voice instructions or preconfigured messages to be broadcast to all buildings on that campus.
- c. A Remote Campus Voice Command Center (CVCC-R), which has duplicate mass notification functionality to the CVCC may also be included where needed.

4. Local Voice Command Center (LVCC)

- a. Each building requires a LVCC at the fire department response point. The EST-3 Control Panel will be a LVCC by default. If the main panel cannot be located at the fire department response point, due to aesthetic or logistical issues, a smaller remote annunciator unit (LVCC-R) may be used. The main panel should not be located below grade as this may prevent radio or cellphone use.

5. The existing system topology is shown in the following figures. Remote annunciators have not been included to keep the illustrations as simple and concise as possible. Remote annunciators are always part of the network wiring for the associated building.

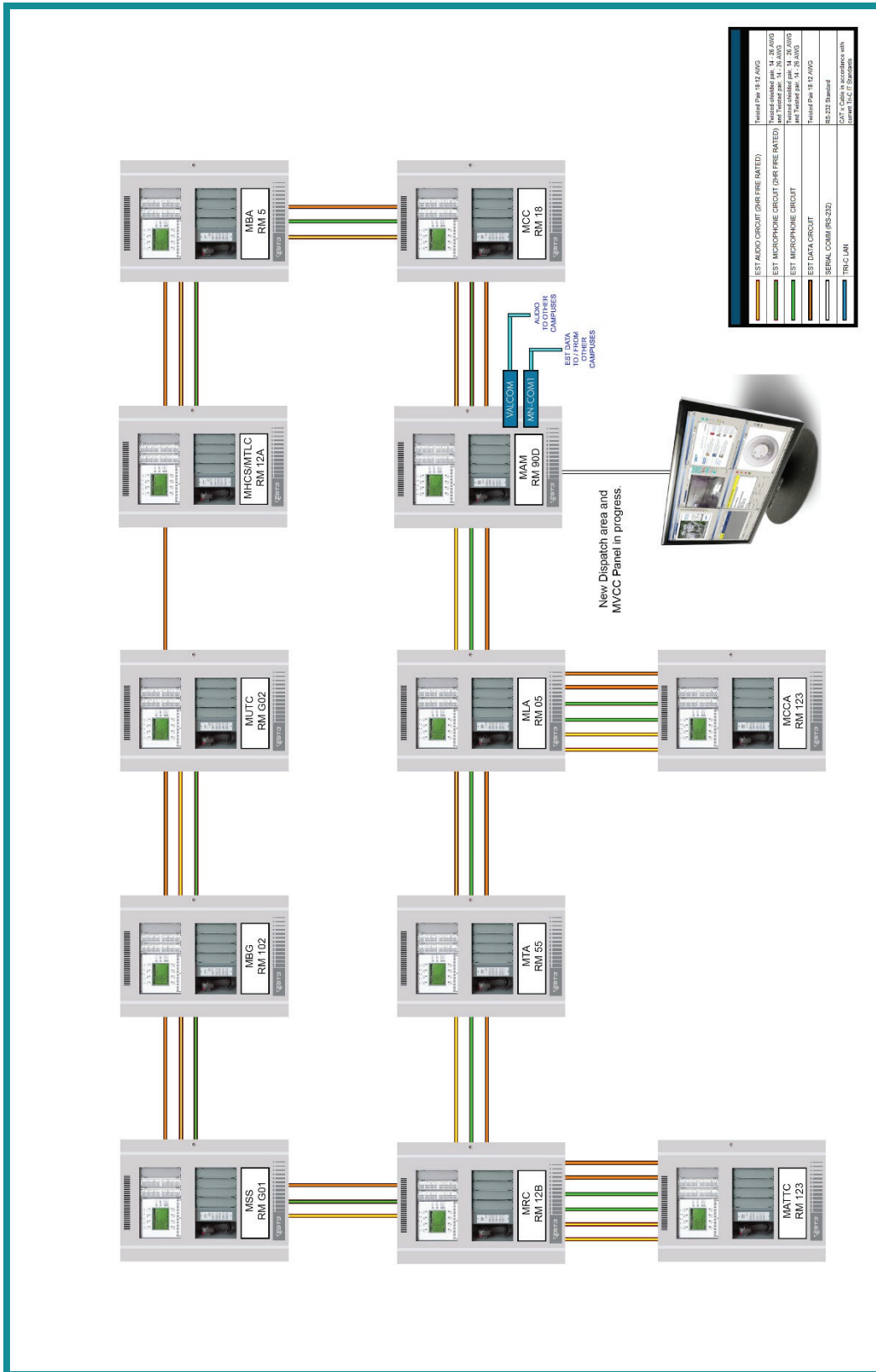

Figure 2.B.5.1 - Metro Campus Existing Topology

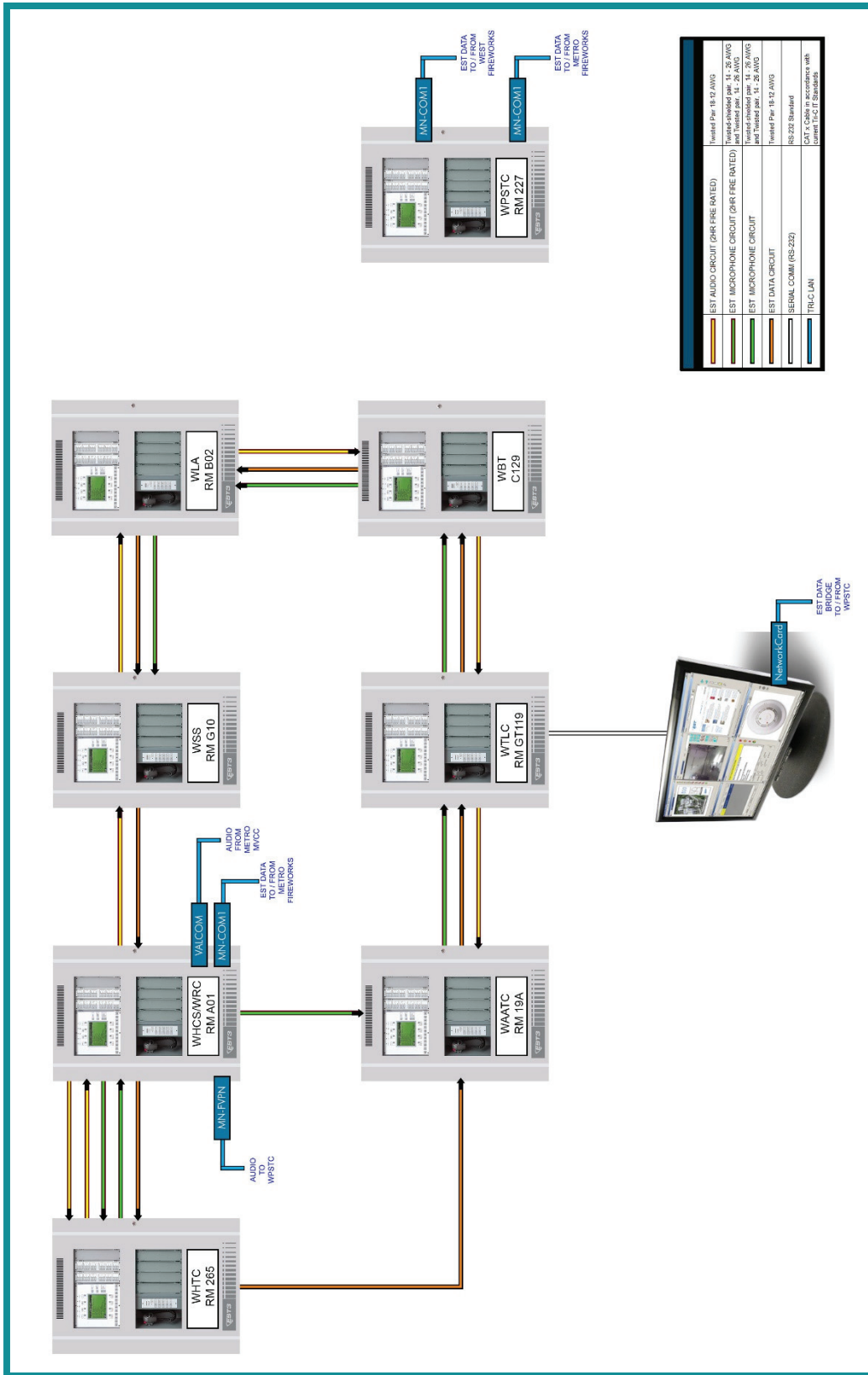

Figure 2.B.5.2. – West Campus Existing Topology

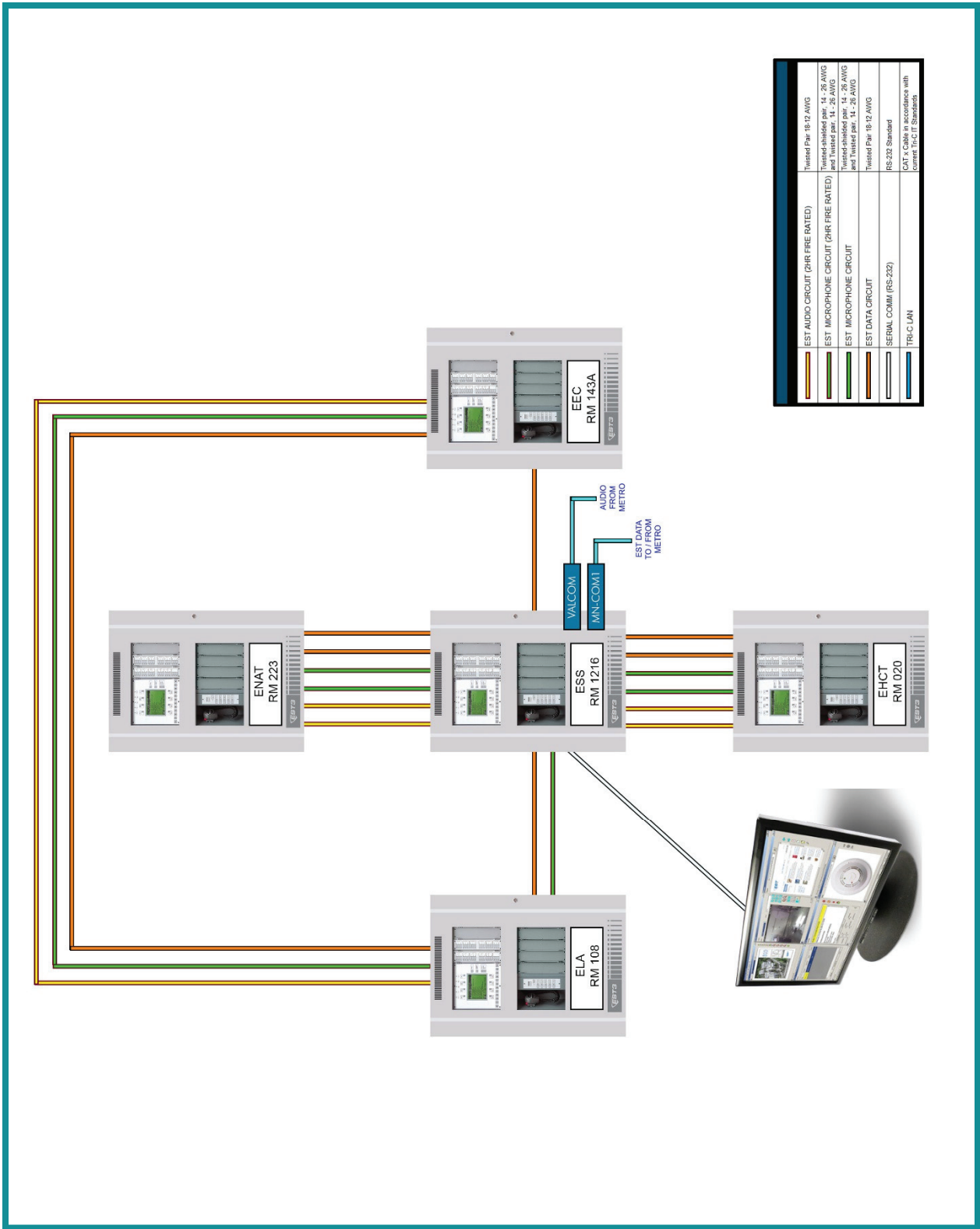

Figure 2.B.5.3. – East Campus Existing Topology



## **SECTION 3: GENERAL REQUIREMENTS**

---



## **SECTION 3 - GENERAL REQUIREMENTS**

### **A. DESIGNER OF RECORD (DOR)**

1. This Document was created to assist the DOR (Designer) in defining the technical aspects of the design. The Designer of the system must still adapt all information provided to the project and is fully responsible for all aspects of their design including but not limited to; verification of existing conditions, verification of current devices, or any other design task which is normally the responsibility of the designer.
2. The Designer shall prepare the design using the philosophy of “Drawings are how to build it and the Specs are what they should buy”. The designer shall coordinate with other designers as required and show all devices on the floor plans. Notes related to installation requirements should also be on the Drawings and not solely in the Specs.

### **B. SCOPE**

1. New systems and extensions of existing systems shall be in accordance with this document.

### **C. CODES**

1. The Ohio Building Code (OBC) – Current Version
2. The Ohio Fire Code (OFC) – Current Version
3. The Ohio Elevator Code - Current Version

### **D. STANDARDS**

1. FM Global Property Loss Prevention Data Sheets - Current Version
2. Fire Alarm, NFPA 72 – Version as referenced by OBC
3. Security, NFPA 731 – Current Version

### **E. STANDARDS - OWNER**

1. “Tri-C Fire Alarm Systems – Design Assistance Manual”
2. “Tri-C Physical Security Systems – Design Assistance Manual”
3. “Tri-C Door Hardware – Design Assistance Manual”
4. ITS “Standard Cabling Installation Procedures and Guidelines”



## **SECTION 4: EQUIPMENT REQUIREMENTS**

---



## SECTION 4 - EQUIPMENT REQUIREMENTS

### A. GENERAL

1. New systems and extensions of existing systems shall be in accordance with this section.
2. In each case, the design must also include any necessary updates to:
  - a. The Master Voice Command Center (MVCC) located at Metro CPSS.
  - b. The Metro Dispatch FireWorks Computer Workstation.
  - c. The FireWorks Computer Workstation at the Campus where work is being performed.
  - d. The Campus Voice Command Center for the Campus where work is being performed.
  - e. The Local Voice Command Centers (LVCC) at the building where work is being performed.
3. New equipment shall be Listed for its purpose by a NRTL.
4. EST fire alarm devices shall be as listed in this document or the newest compatible replacement device for the listed model number.
5. New field device requirements shall be in accordance with applicable codes and the Owner Specific Requirements.

### B. FIRE ALARM CONTROL UNITS / PANELS

1. The following table and illustrations define the requirements for new panels.

REQUIRED FIRE ALARM CONTROL EQUIPMENT			
TYPE	DEVICE	ADDITIONAL DEVICES	NOTES
Fire Alarm Control Unit	EST-3	As required	
Remote Annunciator / Voice Command	3-ANNCPU	3-12SY, 3-LCD,3-REMIC	
NAC	BPS6A/BPS10A	SIGA-CC1(S)	<i>Also used when expanding audible visual alarms in existing areas</i>

*Table 4.B.1 – Control Equipment Requirements*

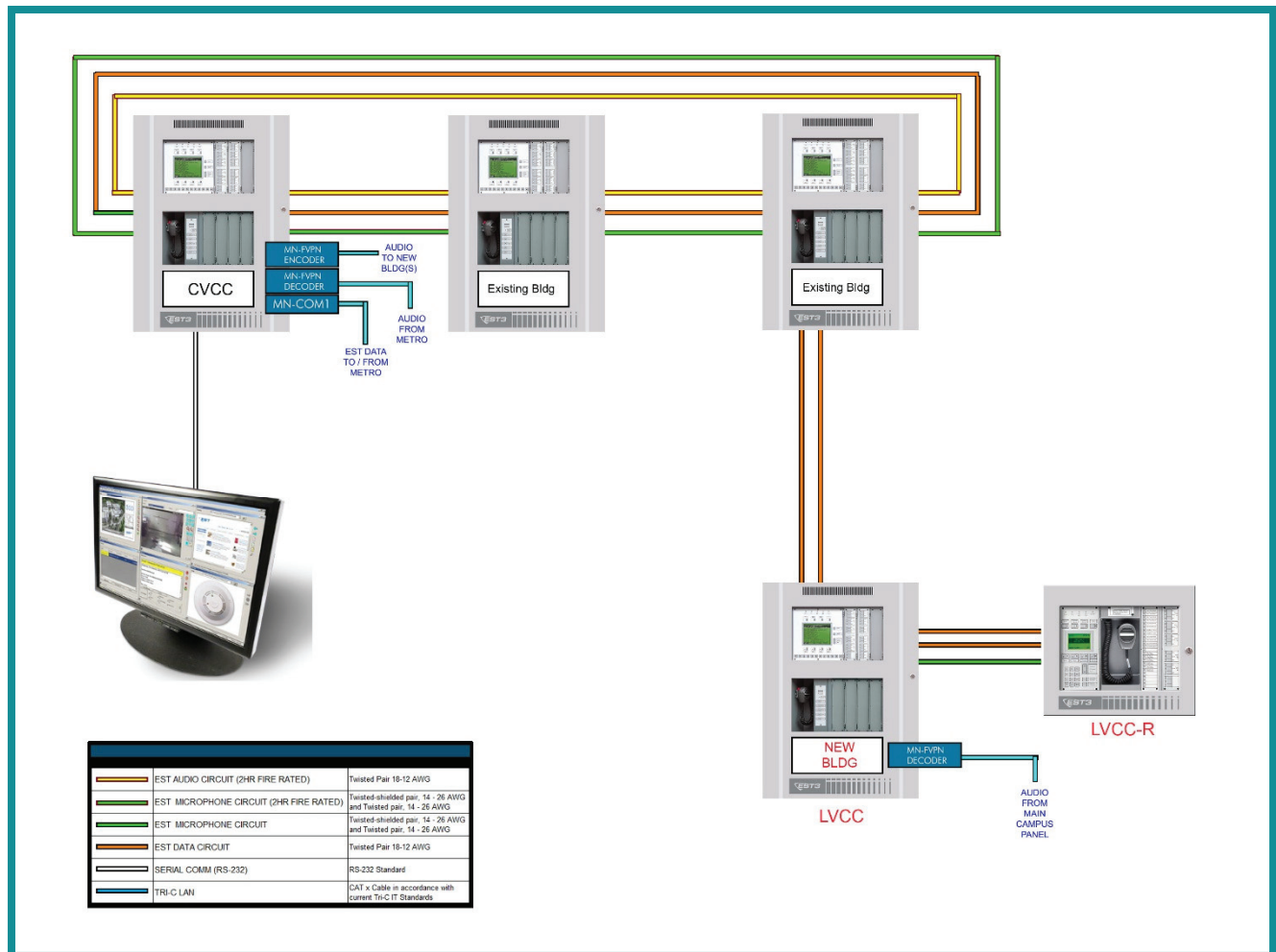

Figure 4.B.1.a – New Building on An Existing Campus

### C. PANEL SWITCHES AND INDICATORS

1. New panel switches and indicators shall be as shown in the following illustrations. In buildings where substantial work is taking place – existing Fire Alarm Control Units / Panels and Annunciators should be updated to this new standard.



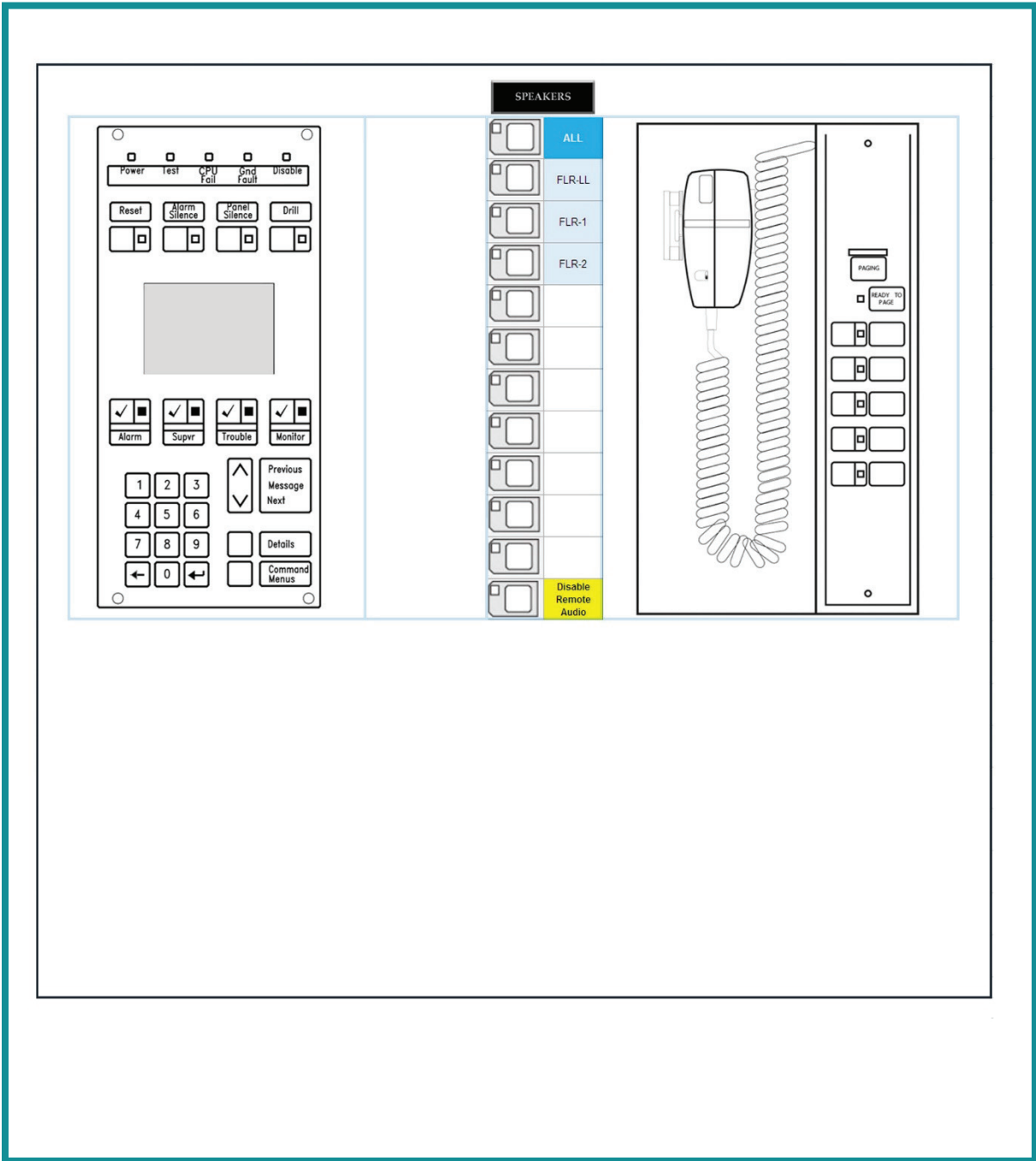
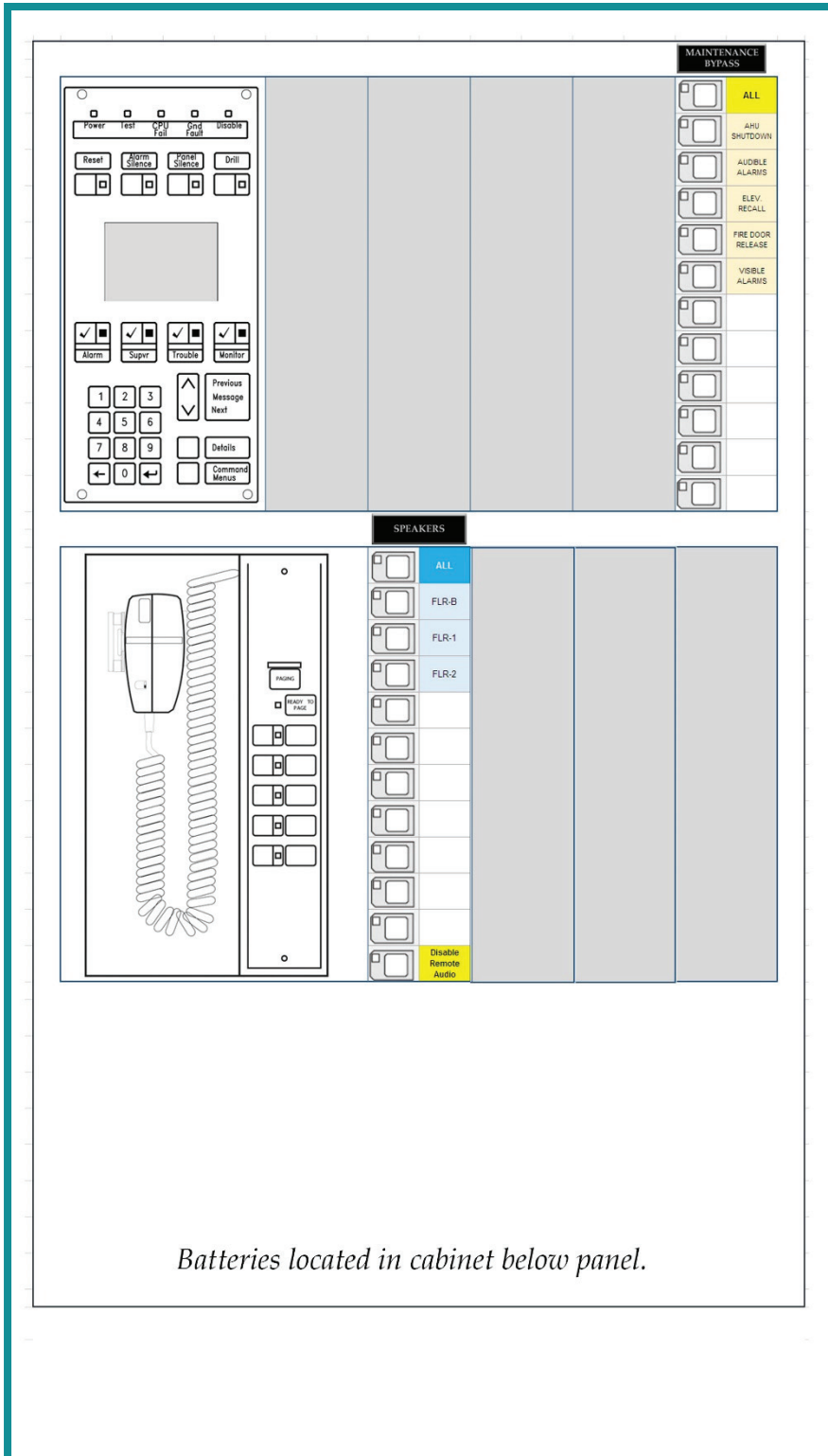

Figure 4.C.1- LVCC-R (Annunciator)



Batteries located in cabinet below panel.

Figure 4.C.2 –LVCC ( FACU) New Building / Existing Campus

**D. APPROVED FIELD EQUIPMENT**

<b>REQUIRED FIRE ALARM DEVICES*</b>			
<b>TYPE</b>	<b>DEVICE**</b>	<b>ADDITIONAL DEVICES</b>	<b>NOTES</b>
Control Relay Modules	SIGA-CR Series	6254A-003 EOL Relay and MR-101 (AIR PRODUCTS) Isolation Relay	<i>Use isolation relay, DC power wiring, and EOL supervisory module with this relay.</i>
Duct Smoke Detector	SIGA-SD	SIGA-LED	
Heat Detector - Fixed Temp	SIGA-HFD	SIGA-SB4	
Heat Detector - Rate of Rise	SIGA-HRD	SIGA-SB4	
Input Modules	SIGA-CT Series		
NAC Booster Power Supply	BPS6A/BPS10A	SIGA-CC1(S)	
Pull Station	SIGA-278		<i>Double Action</i>
Smoke / Heat Detector	SIGA-PHD	SIGA-SB4	
Smoke Detector	SIGA-PD	SIGA-SB4	
Speaker	G4-S2		<i>White, 25V, No markings</i>
Speaker w/ Strobe	G4-S2VM		<i>White, 25V, No markings</i>
Strobe	G1-VM or G1RF-VM		
<p>*All devices are made by EST unless otherwise noted.  ** For devices outside their environmental specifications use an appropriate conventional device connected to an addressable monitor point.</p>			

*Table 4.D.1 – Required Fire Alarm Field Devices*

## E. OWNER SPECIFIC REQUIREMENTS

1. **Annunciator Panels (LVCC)** - Annunciator panels must include voice capability.
2. **Combination Smoke / Heat Detection (Rate of Rise):** shall be provided in the following locations:
  - a. Housekeeping Closets
  - b. Electrical or ITS Rooms and Closets
  - c. Storage Rooms used primarily for the storage of paper (which is not in filing cabinets) or other easily combustible materials.
  - d. Storage Rooms used for the storage of chemicals or aerosols
3. **Duct Smoke Detection:** Provide Duct Detectors with remote indicators but no test switch. Configure devices as a "Supervisory" signal and not as a general "Alarm."
4. **Heat Detection (Fixed Temperature):** shall be provided in the following locations when sprinklers are not present:
  - a. Mechanical Rooms
  - b. Maintenance Shops
  - c. Instructional areas with equipment that may quickly increase the temperature of the room  
e.g. kilns.
5. **Heat Detection (Rate-of-Rise):** shall be provided in Instructional areas where welding, woodworking, or any other use of open flames will take place.
6. **Knox Boxes:** Knox boxes are not used.
7. **Pull Stations:** Manual pull stations shall be provided throughout and the exception for a sprinkled building shall not be taken.
8. **Speakers:** Provide exterior speakers to provide coverage of areas surrounding building. Exterior speakers shall be on a dedicated speaker circuit which may be controlled separately from interior speakers.

## **SECTION 5: COLLEGE SERVICE VENDOR**

---



## **PART 5 - COLLEGE SERVICE VENDOR**

### **A. DESIGN COORDINATION**

1. Coordination with the College Service Vendor must take place whenever changes are made to the system. The Designer is responsible for coordinating with the College's Service Vendor during the design phase.

### **B. ALLOWANCES**

1. The Contractor shall include an Allowance, in their bid, for the services required of the College Service Vendor. Allowances may be used, in accordance with the General Conditions, for the activities listed in Table 5.B.1.

### **C. CONTRACTOR COORDINATION REQUIREMENTS**

1. The Contractor shall coordinate and provide information and/or documentation to the College Service Vendor as required.
2. Device Numbering: The Contractor shall coordinate with the College Service Vendor to obtain the device numbers which will be used. The contractor shall label each device with a number on the red-line drawings.
3. Device Descriptors: The Contractor shall coordinate with CPSS to create approved device descriptors to be used in programming.
4. Device List: The Contractor shall provide the College Service Vendor with a Device List which includes:
  - a. The approved Device Descriptor
  - b. The corresponding device number as shown on the record drawings.
  - c. The (programming) barcode label from the corresponding device.
5. Drawings: A copy of the "red-line" drawings and an electronic copy of the record drawings, in CAD format, with backgrounds and updated device locations included.

SCOPE	Electrical			Programming			Misc			ALLOWANCE
	Supervision and Coordination of disconnects and tie-in by Contractor	Disconnect and tie-in of fire alarm circuits	Installation of wire/cable, panel hardware, devices, etc.	Coordination with Supplier and Contractor for panel programming	Panel programming	Programming the Fire Works Computers	Witness testing	Perform Testing	Update the College's master record drawings	
New Panel / Building Being Added	•			•		•	•	•	•	\$10,000
Major addition to an existing panel	•			•		•	•			\$5,000
Minor addition, relocation or removal (Less Than 3 Devices)		•	•		•			•	•	\$1,500

Table 5.B.1 –Scope of Allowances For Service Vendor



**APPENDIX A**  
**EXISTING CONTROL PANEL LOCATIONS**



## APPENDIX A - EXISTING FIRE ALARM PANEL LOCATIONS

BLDG	PANEL	LOCATION	NOTES
BUC	FACU	FLR-1	
CCE	FACU	FLR-1 Rm 127	<i>Simplex 4010</i>
CCE	FACU	FLR-1 Rm 128	<i>Simplex 4005</i>
CCE	FACU	FLR-1 Rm 129	<i>Simplex 4009</i>
CCE	ANN	FLR-1 South Main Entrance	<i>Simplex</i>
CCW	FACU	FLR-1 Rm 116 Janitor Closet	<i>ADT Panel</i>
CCW	NAC	FLR-1 Rm 117 Electrical Room	<i>Fire-Lite FCPS-24FS8</i>
CCW	ANN	FLR-1 East Vestibule	<i>ADT Panel</i>
DIST	FACU	FLR-G Rm 001B ITS Room	<i>Simplex panel serves as FACU for the building</i>
DIST	FACU	FLR-G Rm 001B ITS Room	<i>EST-2 Transmits Alarm and Trouble to CPSS Dispatch</i>
EEC	FACU	FLR-1 Rm 143A Electrical Closet	
EEC	NAC	FLR-B Electrical Rm	
EEC	NAC	FLR-1 Rm 143 Electrical Room	
EEC	NAC	FLR-1 Rm 143 Electrical Room	
EHCT	FACU	FLR-LL Rm 020	
ELA	FACU	FLR-1 Rm 108 Electrical Room	
ELA	NAC	FLR-1 Rm 108 Electrical Room	
ELA	NAC	FLR-1 Rm 108 Electrical Room	
ELA	NAC	FLR-2 Rm 229 Electrical Room	
ELA	NAC	FLR-1 Rm 108 Electrical Room	
ENAT	FACU	FLR-2 Rm 223 ITS	
EPH	FACU	FLR-G Pumphouse	Not on network
ESS	FACU	FLR-1 Rm 1216 Electrical Rm	
ESS	NAC	FLR-1 Rm 1216 Electrical Rm	
ESS	NAC	FLR-1 Rm 1216 Electrical Rm	
ESS	NAC	FLR-1 Rm 1216 Electrical Rm	

## APPENDIX A - EXISTING FIRE ALARM PANEL LOCATIONS

APPENDIX A - EXISTING FIRE ALARM PANEL LOCATIONS			
BLDG	PANEL	LOCATION	NOTES
ESS	NAC	FLR-2 Rm 2221 Electrical Rm	
ESS	NAC	FLR-2 Rm 2221 Electrical Rm	
ESS	NAC	FLR-2 Rm 2221 Electrical Rm	
ESS	NAC	FLR-3 Rm 3109 Electrical Rm	
HMC	FACU	FLR-1 Main Entrance	
HMC	NAC	FLR-1 Rm 162	
HMC	ANN	FLR-1 North Main Entrance	
JSTC	FACU	FLR-1 Main Entrance	
MATTC	FACU	FLR-1 Main West Entrance	
MAM	FACU	FLR-G Rm 90D CPSS	
MAM	NAC	FLR-G Rm 5A Garage Electrical Rm.	
MAM	NAC	FLR-G Rm 91B Loading Dock Electrical Rm.	
MAM	NAC	FLR-G Rm 91B Loading Dock Electrical Rm.	
MAM	NAC	FLR-1 Rm 116 Electrical-Mechanical Rm	
MBA	FACU	FLR-G Rm 5 Garage Electrical Rm.	
MBA	NAC	FLR-G Rm 5 Garage Electrical Rm.	
MBA	NAC	FLR-G Rm 5 Garage Electrical Rm.	
MBG	FACU	FLR-1 Rm 102 Office	
MBG	NAC	FLR-1 Rm 104 Electrical Rm	
MCC			
MCC			
MCC			
MHCS	FACU	FLR-G Rm 12A Electric Equipment	
MHCS	NAC	FLR-G Rm 12A Electric Equipment	
MHCS	NAC	FLR-1 Rm 117 Electrical Rm	
MHCS	NAC	FLR-2 Rm 225 Electrical Rm	

## APPENDIX A - EXISTING FIRE ALARM PANEL LOCATIONS

BLDG	PANEL	LOCATION	NOTES
MHCS	NAC	FLR-2 Rm 210 Electrical Rm	
MHCS	NAC	FLR-3 Rm 308 Electrical Rm	
MHCS	NAC	FLR-G Rm 12A Electric Equipment	
MHCS	NAC	FLR-1 Rm 104A Electrical Rm	
MHCS	NAC	FLR-1 Rm 106E Electrical Rm	
MLA	FACU	FLR-G Rm 5 Garage Electrical Rm.	
MLA	NAC	FLR-1 Rm 118M Conference Electrical Rm	
MLA	NAC	FLR-2 Rm 223 Electrical Rm.	
MLA	NAC	FLR-G Rm 5 Garage Electrical Rm.	
MLA	NAC	FLR-3 Rm 323 Electrical Rm.	
MRC	FACU	FLR-G Rm 12B Electric Rm.	
MRC	NAC	FLR-G Rm 12B Electric Rm.	
MRC	NAC	FLR-G Rm 12B Electric Rm.	
MRC	NAC	FLR-1 Rm 106 Storage Rm.	
MSS	FACU	FLR-B Mechanical Rm.	
MSS	FACU	FLR-5 Rm 504 Server room	<i>Covers only the server room</i>
MSS	NAC	FLR-1 Rm 136B Janitorial Rm.	
MSS	NAC	FLR-2 Rm 203B Janitorial Rm.	
MSS	NAC	FLR-4 Rm 403A IDF Closet via Mens Rm	
MTA	FACU	FLR-G Rm 51 Office	
MTA	NAC	FLR-G Rm 51 Mechanical	
MTA	NAC	FLR-G Rm 51 Mechanical	
MTA	NAC	FLR-G Rm 51 Mechanical	
MUTC	FACU	FLR-B Electrical Rm	
MUTC	NAC	FLR-B Electrical Rm	
MUTC	NAC	FLR-2 North Electrical Closet	

## APPENDIX A - EXISTING FIRE ALARM PANEL LOCATIONS

BLDG	PANEL	LOCATION	NOTES
MUTC	NAC	FLR-2 North Electrical Closet	
WAATC	FACU	FLR-1 Rm 19A Electrical Closet	
WAATC	NAC	FLR-1 Rm 12 Electrical Rm	
WBT	FACU	FLR-1 Rm C129 Mechanical	
WBT	NAC	FLR-1 Rm C129 Mechanical	
WBT	NAC	FLR-2 Rm C259 Mechanical	
WHCS/WRC	FACU	WHCS FLR-B Rm A-01 Tunnel Electric Equipment	<i>FACU Serves WHCS and WRC</i>
WHCS/WRC	NAC	WHCS FLR-B Rm A-01 Tunnel Electric Equipment	
WHCS/WRC	NAC	WRC FLR-2 Rm F-206A W. Tower Mechanical Rm	
WHCS/WRC	NAC	WHCS FLR-1 Rm A147 Mechanical Rm	
WHCS/WRC	NAC	WHCS FLR-2 Rm A242 Mechanical Rm	
WLA/WTA	FACU	WTA FLR-B Rm B-02 Tunnel Electric Equipment	<i>FACU Serves WLA and WTA</i>
WLA/WTA	NAC	WLA FLR-1 Rm B161 Mechanical Rm	
WLA/WTA	NAC	WLA FLR-2 Rm B244 Mechanical Rm	
WLA/WTA	NAC	WTA FLR-B Rm B-02 Tunnel Electric Equipment	
WLA/WTA	NAC	WTA FLR-1 Rm B-02 Tunnel Electric Equipment	
WPSTC	FACU	FLR-2 Rm 227 Mechanical	
WPSTC	NAC	FLR-2 Rm 227 Mechanical	
WPSTC	NAC	FLR-2 Rm 227 Mechanical	
WPSTC	ANN	FLR-1 West Vestibule	
WSS	FACU	FLR-G Rm G-10 Electrical Rm.	
WSS	NAC	FLR-G Rm G-10 Electrical Rm.	
WSS	NAC	FLR-1 Rm G128 Electrical Closet	
WSS	NAC	FLR-1 Rm G100 Electrical Closet	
WSS	NAC	FLR-2 Rm G240 IDF Room	
WSS	NAC	FLR-2 Rm G204 Storage Rm.	
WTLC	FACU	FLR-1 Rm GT119 Mechanical Rm	
WTLC	NAC	FLR-1 Rm GT121 Storage Rm	
WTLC	NAC	FLR-1 Rm GT204 Mechanical Rm	
WSHCS	FACU	FLR-1 Main Lobby	

# APPENDIX B

## LABELING





# APPENDIX C

## CONTACTS



## **OWNER**

### **Anthony Jackson**

Executive Director, Emergency Management/ Fire Safety

Jerry Sue Thornton Center Rm 175

(216) 987-3012

[Anthony.Jackson@tri-c.edu](mailto:Anthony.Jackson@tri-c.edu)

### **Tri-C Police Dispatch**

Phone (216) 987-4325

## **COLLEGE SERVICE VENDOR FOR FIRE ALARM SYSTEMS**

### **Bay Mechanical and Electrical Corporation**

Jason Neuschaefer, LEED AP BD+C

Project Manager

Office:440-989-4083

Cell: 440-759-3131

This document has been prepared by Gryffon LLC.  
[www.gryffon.pro](http://www.gryffon.pro)

# CUYAHOGA COMMUNITY COLLEGE

## *STANDARD CABLING INSTALLATION PROCEDURES AND GUIDELINES*

ITS Network Services has the responsibility of planning, developing, managing and maintaining the most effective, efficient and economic communications network possible. To ensure that Cuyahoga Community College's voice and data communications needs are met, ITS Network Services (Network Services) must be consulted during the initial planning of new construction or renovation of existing space. The Structured Cabling Specification for Data and Fiber is constantly changing due to the implementation of new technologies, and as such this document should be checked frequently for updates. The Universal Wiring Plan, UWP, is based in part on the *BICSI, EIA/TIA 569 and City of Cleveland electrical codes and standards*. All construction/renovation projects on campus requiring telecommunications services from an outside vendor must consider this document as an integral part of their construction/renovation.

Network Services is responsible for the oversight of the installation and maintenance of this voice and data network infrastructure which in turn provides critical applications such as phone services, voicemail, electronic mail, web access, multimedia, life safety and security related support services. In addition; emergency phones, E911 compliance and a host of other administrative applications require the implementation of a *highly redundant and reliable* voice and data network infrastructure.

It is the purpose of this document to set the standards for new construction to meet the specifications of the existing network, in order for Network Services to better support the college and its mission. The design of the voice and data network is an integral part of the ***budgeting, development and planning*** process of a project. It is critical to get Network Services involved at the very beginning of all projects.

Project Manager should supply the following information:

1. A description on the scope of the project in regard to voice and data.
2. Project time frame.
3. Budget account information for charge back (if applicable).
4. End user contact information (i.e. name(s), phone, email, and fax).
5. Building and Floor prints with accurate room numbers.
6. Building and Floor prints with voice and data locations.
7. AutoCAD drawing format files of the telecom, electrical and furniture.
8. Provide vendor availability for walkthrough at job site before bidding process.
9. Should include labor cost for vendors at prevailing wage.

Each project will provide a set of Telecommunications drawings (T drawings) separate from the electrical drawings (E drawings), and furniture drawings. These drawings will illustrate the following:

1. All voice and data locations.
2. Equipment room locations (CMDf/MDF/IDF/Classroom).
3. Cable pathways and risers.
4. Building entrances.
5. HVAC systems in network equipment locations.
6. Final room numbers and furniture layout.
7. Electrical layout.

### **Specifications**

*Any deviations from the standards below must be approved by ITS Network Services before installation*

## I. CABLE TYPES

- A. All cables installed exposed in occupiable spaces or in ceilings not enclosed in conduits must be FEP fire rated for plenum type ceiling areas.
- B. All fiber optic cables installed in ceilings must be installed in conduits or plastic inner duct; if exposed in occupiable spaces or in ceilings which are air plenum areas, the plastic inner duct must be plenum rated.

## II. CABLE INSTALLATION

- A. Cables should be routed in existing cabling trays or conduits where available and/or possible.
- B. Cables not routed in trays or conduits must be suspended above the ceiling via bridal rings, cables ties or over existing structural supports and not laying on sprinkler or water lines. Minimum height above the ceiling tiles should be at least six inches where possible, and preferably to two or three feet.
- C. Once installed, cables should be neatly strung with all slack removed so as to minimize sagging.
- D. Cables should not be kinked, excessively twisted or severely bent at any point; minimum manufacturer bend radius for each cable type should be maintained at all times.
- E. Cables which cannot be installed in ceilings and not enclosed in trays, conduits or raceways must be fastened to walls or mounting surfaces with appropriate rings, clamps or ties and neatly routed via a path that minimizes the potential for damage.
- F. Cables should be neatly dressed and logically routed in CMDF/MDF/IDF/Classroom areas through D-rings to their appropriate termination points; all cables must be permanently numbered or labeled either on the termination equipment or directly on the cable jacket.
- G. Excess cable at the station end should be neatly tied in a loop above the point where the cable exits the ceiling. All cables must be permanently numbered directly on the cable jacket and face plate. See how to number the cable location Cable Numbering Requirement paragraph.

## III. PLENUM CEILING

- A. All cable to be installed must be in conduit with push-on plastic bushings. Cable tray system must be replaced with conduit and pull box infrastructure.
- B. Conduit must be home run from each information outlet to an accessible pull box, and then from the pull box large conduits to the IT closet.
- C. All conduits 1" or larger can have no more than three (3) 90-degree bends, with push-on plastic bushings on the termination end.
- D. Conduit from the pull boxes to the IT closet must be sized-in appropriately and filled to no more than 40% of capacity.
- E. No conduit continues more than 100' without a pull box.
- F. Wireless access points should be 84 inches above finished floor in application, assume drops for wireless access every 50 feet.

## IV. DRYWALL CEILING

- A. The conduit must be home run from each office location all the way to the cable tray in the corridor.
- B. Cable tray can be used to run low voltage other cables.
- C. Access panels must be installed every 50 feet apart and just outside the IT closet.
- D. Access panels are minimally 2' x 2' and must meet fire rating specifications.
- E. All conduits 1" or larger can have no more than three (3) 90-degree bends, with push-on plastic bushings on the termination end.
- F. No conduit continues more than 100' without a pull box.
- G. Wireless access points should be 84 inches above finished floor in application, assume drops for wireless access every 50 feet.

#### V. STATION RECEPTACLE INSTALLATION

- A. Two data cables and station receptacles should be installed for any new individual device location needed, as near as possible to designated locations; receptacles should be accessible and protected from potential damage wherever possible.
- B. Station receptacles must be securely fastened to walls, office partitions or power poles whether the cables are installed internal or external to the mounting surface.
- C. Externally mounted raceways and receptacle bases installed on cinderblock, brick or other masonry surfaces must be anchored with appropriate fasteners.
- D. Station jacks and connectors must be installed according to manufacturers' specifications; spare pairs from voice/fax jacks should be neatly wrapped around the voice cable jacket.
- E. All receptacles must be labeled and/or numbered with consecutive and appropriate station designations and continue existing labeling numbers whenever existing labeling is in place; base plates should be numbered as well as covers in case of loss or damage to the cover. All rack mounted receptacles should be labeled consecutively and to match their wall counterparts.
- G. The RJ-45 face plate modular couplers should be blue, unless otherwise specified.
- H. All the wall plates for data plug color specified by the contractor to match the color of other face plates in the room.
- I. All data and cable should be CAT6 cable, blue, unless otherwise specified.
  - J. All network cabling faceplates, wall jacks, rack jacks, rack blocks and associated cabling infrastructure pieces must be manufactured by Panduit.
  - K. The current standard for sockets and receptacles are Panduit MiniCom.

#### VI. TESTING AND DOCUMENTATION

- A. Data station cables must be tested for length, continuity, wire mapping and crosstalk, and adhere to CAT6 functionality standards as applicable in ANSI/TIA/EIA.
- B. Fiber optic cables must be tested for dB loss readings and adhere to the specific fiber type functionality standards as applicable in TIA/ISO.
- C. Documentation provided to the college must include all of the above test results as well as maps of floor plans indicating receptacle designation locations and physical cable routes.

## VII. CAMPUS MAIN DISTRIBUTION FRAME / MDF / IDF

- A. CMDF/MDF/IDF should always be a separate room, and not shared with other utility services (especially electrical services).
- B. When possible, room shall not be adjacent to the electrical distribution room or next to elevator or elevator service rooms.
- C. CMDF/MDF/IDF room size should be minimum 8' x 10' or determined by the size and use of the network hardware in the building. For buildings exceeding 50,000 ASF, room size shall increase a minimum of 30 square feet per each additional 50,000 ASF. As room size increases, a 3:2 length-to-width ratio shall be maintained.
- D. In the event that program space is assigned on the same level as the MDF Room, the MDF Room shall be sized and provisioned to serve as an Intermediate Distribution Frame (IDF) Room. This includes pathways for station cable and riser cable.
- E. All rooms need to be environmentally controlled to ensure reliability of sensitive electronic equipment.
- F. Backboards for CMDF/MDF/IDF are to be ¾" plywood wood on one side, and painted with flat light colored fire-retardant paint on all sides. All usable walls should have backboards.
- G. HVAC Equipment: Provide dedicated HVAC equipment required to meet 24/7 operational requirements of network hardware. Condenser cooling water and refrigerant piping shall be routed outside the CMDF/MDF/IDF.
- H. Locate the door of the MDF Room on one of the shorter walls of the room. The door should be offset toward either side of this wall. The door swing shall not in any way restrict access to riser sleeves, entrance conduits, cable tray, or the main backboard. An outward door swing is preferred. Coordinate with project architect. The door shall be 36-inches wide and 6-feet 8-inches high. It shall be secured with a secure proximity card reader, connected to Campus Police access systems, and a key core as a backup.

### **Network Backbone Cable Requirements:**

1. CMDF to MDFs with 24 strand single-mode and 18 strand multi-mode OM3 fiber optic cables.
- AND-
2. MDF to IDFs with 24 strand single-mode and 18 strand multi-mode OM3 fiber optic cables.

The backbone for data will be the cables from the CMDF (Campus Main Distribution Frame) to each building MDF (Main Distribution Frame) and the cables from each building MDF to all IDF's (Intermediate Distribution Frame) in that building.

### **Analog Circuit Backbone Cable Requirements (done by exception now, per project):**

3. CMDF to MDFs with (1) 100 twisted pair cable CAT4 cable and MDF to IDF with (1) 50 twisted pair cable CAT4 cable; both terminated on 110 punch down blocks.



The backbone for voice/fax will be the cables from the CMDF (Campus Main Distribution Frame) to each building MDF (Main Distribution Frame) and the cables from each building MDF to all IDF's (Intermediate Distribution Frame) in that building.

#### VIII. NETWORK DISTRIBUTION CABLE REQUIREMENT

Termination of all cabling will be a modular design to minimize maintenance, cost of moves, additions and changes. The faceplate design will be capable of supporting a variety of termination configurations.

The Location of CMDF, MDF and IDF should be center of the building and it should top of each other:

- Two 4" conduits between floors (CMDF/MDF/IDF).
- Ethernet cable distance should not exceed 270'. **If distance is more than 270' from the IT closet to faceplate another MDF/IDF should be created.**

Each and every installed faceplate will have a base or minimum configuration consisting of:

- Two (2) UTP CAT6 cable with RJ-45 connectors for Ethernet

#### IX. ELEVATOR PHONES

A. Elevator phone line installations should be documented and terminated by the Electrical Contractor or cable installer from the CMDF/MDF/IDF/demarc to the Elevator phone. The current standard for connectivity is to use POTS or analog lines for Elevator phones.

#### X. EMERGENCY PHONES

A. Emergency phone models and location are determined in cooperation with Campus Police, per project.

#### XI. WIRELESS ACCESS POINTS

- A. All wireless access points are to be mounted on the ceiling or highest horizontal surface, including acoustic tiles
- B. Manufacturer instructions and guidelines are to be followed at all times, to ensure proper installation.
- C. Cabling to wireless access points needs to be **Cat6a**, to support 2.5/5/10Gbs at support distances.
- D. Minimum 10' service loop is to be looped in the ceiling, to allow for minor adjustments to improve wireless signal.

#### XII. BACKBONE WIRING FOR CMDF/MDF/IDF

Unless otherwise specified, all fiber, copper, and backbone connectivity will be terminated on plywood backing, on the wall behind the network equipment racks.

Optical Fiber Cable used by the college is manufactured by Corning:

- 8-10.5/125 Microns single mode fiber LC terminated in the patch panel

- 50/125 um OM3 multimode fiber cable LC terminated in the patch panel
- Vendor produce all certifications on cabling using OTDR testing tool and follow TIA 568C.0 TSB 140 and ISO 14763-3 to ensure installation meets specifications.

Data Cable used in the college manufactured by General Cable or equivalent:

- Category 6 terminated Panduit MiniCom Panels.
- Four (4) pairs Category 6 UTP terminated in the receptacles.
- CMDF/IDF/MDF Basic Room Requirement
- Vendor shall produce all certifications on cabling prior to installation to ensure safe installation according to TIA/EIA standards.

Each CMDF/MDF/IDF room should be 8' x 10' and consist of the following:

- Four (4) L6-30R receptacles
- In CMDF and MDF, two 100 amp 208v circuits delivered through dual-pole (50 amp per pole) breakers should be delivered to a 4-wire bare end connector, for use with two high-capacity UPS systems.
- A minimum of Three (3) 4'x8' 3/4" fire treated plywood mounted backboards
- Two (2) 4" core bores in the floor for vertical fiber.
- One (1) 10" long 4" high and 12" wide cable tray one (1) T fitting in the end of the cable tray or as identified.
- Secure proximity card reader, connected to Campus Police access systems, programmed to limit access to IT/maintenance/Police
- 2 Quad 115 Volt, 20 Amp outlets.

### XIII. STANDARD NETWORK EQUIPMENT

Network Services will specify equipment as needed, per project, and installs all network equipment, unless otherwise specified. Network Services may request assistance in installation of wireless access point hardware in a project.

### XVIII. STANDARD WAN OR MAN COMMUNICATION CONNECTIVITY FOR CMDF (new campuses only)

Two (2) 10Gb or 1Gb circuits for communications (minimum), College-provided

### XIX. STANDARD EQUIPMENT RACKS FOR CMDF/MDF/IDF (quantity dependent on equipment)

Chatsworth 4-post open network equipment rack with wire management; ITS will specify this exact model per project.

### XX. STANDARD EQUIPMENT FOR CLASSROOM COMPUTER LABS (quantity may change based on number of PCs)

ITS determines, per project, if a dedicated switch is needed for a classroom computer lab. Each classroom computer lab to consist of the following minimum:

- One (1) 1U network switch
- One (1) 19" wall-mounted network equipment cabinet, locking, fully enclosed, with fan, and mounted high, near the ceiling. Exact model to specified by ITS, per project.

One (1) fiber patch panel  
One (1) Cat6 patch panel  
One (1) wire management and duplex 110 volt, 20 amp power for the switch and fan

All lab wiring needs to be terminated in the room standard lab cabinet. Termination of all cabling will be a modular design to minimize maintenance, cost of moves, additions and changes. The faceplate design will be capable of supporting a variety of termination configurations.

Each student desk must have one (1) UTP CAT6 cable RJ-45 connector for Ethernet, installed faceplate (Panduit) and two (2) power outlets for CPU and monitor.

All fiber cable runs will be home run from the lab switch cabinet to CMDF or MDF. The 12 strand fiber from the cabinet to MDF must be terminated properly and document any losses. All fiber used must be standard 50/125 OM3 multimode or single mode Fiber 8-10.5/125 microns, depending on the location need. All fiber for a classroom computer lab should be terminated in the fiber patch panel in the wall-mounted network equipment cabinet.

**Note - For Video**

*The final equipment identification dependent on final drop location and distance.*

XXI. PROCEDURES AND RESPONSIBILITIES

- A. Work areas should be kept clean and orderly; areas where work has been completed must be restored to their original condition.
- B. Safety at the work area must be a priority at all times; ladders and equipment in hallways should not be left unattended for extended periods of time.
- C. Ceiling tiles should be closed at the end of every work day whenever possible; all ladders and equipment must be stored in appropriate locations.
- D. Maximum cooperation with personnel occupying areas where work is occurring should be maintained at all times; scheduling work at their convenience when necessary should always be facilitated.
- E. All personnel performing work should be professional and courteous at all times.

XXII. LAN CONNECTION REQUIREMENTS

- A. Two (2) ethernet drops per office or device location minimum, unless otherwise specified.
- B. Four (4) drops per classroom. Install the drops opposite wall of each other - two near the teacher's desk or in an ATC cabinet when present and the other two on the opposite wall.
- C. Two (2) drops installed next to the printer (central) office location.
- D. Keep the drops way from being under the windows.
- E. Have an alternate site ready in case the drop cannot be installed.
- F. Data drops cannot be installed between shelves and cabinets.
- G. Try to install the drops as close to AC outlets as possible. All drops should be installed next to desk or underneath of the desk where they can be easily accessible.
- H. Do not have a drop located where it will be going across the floor or in front of the door.
- I. All drops to be placed behind furniture are to have a patch cord already pre-installed prior to furniture installation, along with the patch cable being individually labeled for identification.

### XXIII. CABLE NUMBERING RECOMMENDATION

- A. All cable numbering and labeling standards must be approved by ITS per project.
- B. The first part of the cabling should be the campus (M for Metro, E for East, W for West, etc.)
- C. Second is the building (LA for ELA, SS for MSS).
- D. Next is the IT closet number. (CMDF/MDF/IDF room number)
- E. Lastly the drop number A01 - A48, B01 – B48, etc. (letter symbolizes patch panel)

#### **Examples:**

**MSS-509-A05** - Metro Campus, Student Services Building, IT closet number 509 and drop number A05.

**WBT-115E-C33** - Western Campus, Business & Technology Building, IT closet number 115E and drop number C33.

**EEC-024-B61** - Eastern Campus, Education Center, IT closet number 024 and drop number B61.

## **CUYAHOGA COMMUNITY COLLEGE FIBER BACKBONE/CABLE NETWORK DESIGN**

### **ANALYSIS & DEFINITION**

This section examines a structured approach that ties together the major Components of a building wiring system. The analysis will reference the following model of building cable components:

- o Station Termination (ST)
- o Horizontal Distribution (HD)
- o Intermediate Distribution Frame (IDF)
- o Vertical Interface Distribution (VID)
- o Main Building Distribution Frame (MDF)
- o Campus-Wide Backbone Subsystem (CMDF)
- o Wide Area Network Interconnection (WAN)

The **Station Termination (ST)** subsystem is the interface between the user's equipment and the building network. An example of a station termination is a modular jack, such as the familiar RJ-45 interface used primarily for data connections.

The **Horizontal Distribution (HD)** subsystem is the wiring that connects the station termination to the IDF. This cabling may be routed through ceilings, ducts in floors and walls, or placed within wall-mounted conduit.

The **Intermediate Distribution Frame (IDF)** is the breakpoint between the Vertical Interface Distribution and the Horizontal Distribution. An IDF is the point where the lines from the vertical cabling are terminated and then patched into the appropriate Horizontal Distribution lines. The IDF may also serve as a connection point for Local Area Network (LAN) equipment.

The **Vertical Interface Distribution (VID)** subsystem, sometimes called the riser system, refers to the transmission facilities that originate from the MDF and are vertically distributed to each IDF in the building. As the vertical cable passes by a given IDF, the cables intended for that IDF are separated from the bundle and terminated.

The **Main Building Distribution Frame (MDF)** is the interface between the campus network and the intra building distribution. The campus subsystem facilities are terminated and are then patched over or cross connected to the Vertical Interface Distribution blocks to provide connection to any IDF in the building. In most buildings, this cross connection should be located in the basement of each building.

The **Campus Main Distribution Frame (CMDf)** is the primary hub for each campus. This subsystem connects the campuses and external locations via the WAN components.

# Cuyahoga Community College Design Assistance Manual

PHYSICAL SECURITY SYSTEMS

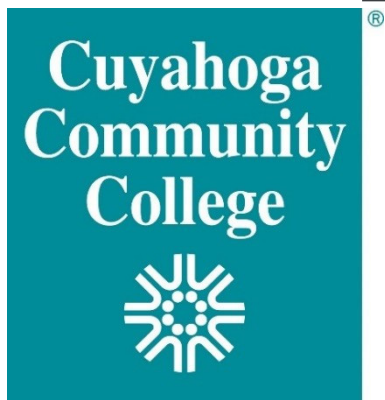

SEC-1  
OCT 2017



## CHANGE HISTORY AND DOCUMENT CONTROL

Rev #	Effective Date	Changes	Approved By
1.0	9/1/2016	Initial	AHJ
2.0	10/1/2017	Clarifications and substantial changes. Substantial reorganization to accommodate door hardware standards.	AHJ
2.1	6/1/2019	Changed approved suppliers list section 2.06.	AHJ

---

Date:

---

Approved By:

---

Unless required otherwise by Ohio Law - external distribution of this document and the data contained herein shall be limited to design and security professionals for use in the design of physical security systems at Cuyahoga Community College (Tri-C). Any other use of college specific information requires the permission of Tri-C. Use of other information requires the permission of Gryffon LLC.

This document shall not be posted on publicly accessible webpages.

---





This document / report has been prepared by:

Dale A. Simmons, CPP, PSP

[Gryffon LLC](#)

[www.gryffon.pro](http://www.gryffon.pro)

Board Certified in Security Management - Registry #12561.





## Table of Contents

### FRONT

Change History and Document Control .....	i
Prepared By.....	iii
Table of Contents.....	v
Introduction.....	1

### PART 1 - SYSTEM OVERVIEW

1.01 STANDARD SYSTEMS .....	4
<i>Table 1.01a Standard Security Systems.....</i>	4
<i>Table 1.01b Legacy Security Systems.....</i>	5
1.02 SUPERVISING STATIONS.....	5
1.03 IMPLEMENTATION STATUS.....	5
1.04 SYSTEM OVERVIEW.....	7
<i>Figure 1.04 System Overview Diagram.....</i>	7

### PART 2 - GENERAL REQUIREMENTS

2.01 GENERAL DESIGN REQUIREMENTS.....	10
2.02 SPECIFIC DESIGN REQUIREMENTS.....	10
2.03 COORDINATION.....	10
2.04 ALLOWANCES.....	11
2.05 STANDARDS.....	11
2.06 APPROVED SUPPLIERS.....	11

### PART 3 - PHYSICAL ACCESS CONTROL SYSTEM (PACS)

3.01 GENERAL .....	14
<i>Figure 3.01 PACS System Overview Diagram.....</i>	14
3.02 WHERE REQUIRED.....	15
3.03 EQUIPMENT REQUIRED.....	16
<i>Figure 3.03a Required PACS Control Equipment.....</i>	16
<i>Figure 3.03b Required PACS Readers.....</i>	16
<i>Figure 3.03c Required PACS Sensors, Switches, and Buttons.....</i>	17

## Table of Contents

### **PART 4 - CCTV SYSTEM**

4.01	GENERAL .....	20
	<i>Figure 4.01 CCTV System Overview Diagram.....</i>	20
4.02	WHERE REQUIRED.....	21
4.03	EQUIPMENT REQUIREMENTS.....	22
	<i>Table 4.03 Camera Types.....</i>	24

### **PART 5 - IDS SYSTEM**

5.01	GENERAL .....	26
	<i>Figure 5.01 IDS System Overview Diagram.....</i>	26
4.02	WHERE REQUIRED.....	27
5.03	OPERATION.....	27

### **PART 6 - DURESS (PANIC) ALARMS**

6.01	GENERAL .....	30
6.02	WHERE REQUIRED.....	30
6.03	EQUIPMENT REQUIREMENTS.....	30

### **PART 7 - EMERGENCY PHONES**

7.01	GENERAL .....	34
	<i>Figure 7.01 EPHONE System Overview Diagram.....</i>	34
7.02	WHERE REQUIRED.....	35
7.03	EQUIPMENT REQUIREMENTS.....	35
7.04	INSTALLATION.....	35
	<i>Figure 7.03 EPHONE Equipment Requirements.....</i>	36

### **PART 8 - LOCKS**

8.01	LOCKS AND KEYS - GENERAL .....	38
8.02	ELECTRIC LOCK TYPES.....	38
	<i>Table 8.02.a - Electric Locks, Single Doors.....</i>	38
	<i>Table 8.02.b - Electric Locks, Fire Rated Single Doors.....</i>	39
	<i>Table 8.02.c - Electric Locks, Double Doors.....</i>	40
	<i>Table 8.02.d - Electric Locks, Fire Rated Double Doors.....</i>	41

## Table of Contents

<b>APPENDIX A - SECURITY DOOR TYPICALS</b>	43
EL-LOCK.....	44
EL-LOCK2.....	45
EL-MON.....	46
EL-MON-OH.....	47
EL-PAN2.....	48
EL-TRM.....	20
EL-TRM2.....	20
<b>APPENDIX B - TYPICAL DEVICE CONNECTION DETAILS</b>	51
<b>APPENDIX C - CONTACTS</b>	55
<b>APPENDIX D - LABELS</b>	57



## INTRODUCTION



Cuyahoga Community College (Tri-C) has standardized its security control systems into a single Security Management System named “Symmetry” by AMAG which integrates Access Control, Intrusion Detection, CCTV, and Emergency Phones into a single interface. Although prevalent in most areas of the college, there are still some that have not been upgraded to the AMAG system.

There are significant safety benefits gained by standardizing to an integrated system. Some potential benefits include:

- Reduced training requirements for dispatchers
- Alarm assessment and response times are enhanced as cameras automatically launch to display the area of concern.

Certain design methods and devices are more likely to perform well in a College environment. The system must be extremely reliable to help maintain a safe and secure environment for campus community members. The complexity of designing extensions to this system necessitated the creation of this guide, which provides the following information for the designer:

- Existing system types and interconnection methods
- Existing system operation and capabilities
- Requirements for extensions to the system

*Note: Unless a component is specifically required for overall system compatibility bid specifications shall list a minimum of three models which meet the minimum performance and quality requirements.*

## CAVEAT

This Design Assistance Manual was created to assist Designers in comprehending the standard systems, devices, and processes used at Tri-C.

The Designer of the system is fully responsible for all aspects of their design including but not limited to: verification of existing conditions, verification of current devices, and any other design task that is normally the responsibility of the Designer.





---

## Part 1 - System Overview

## 1.01 STANDARD SYSTEMS

The existing, standard Electronic Security Systems (ESS) are comprised of separate systems integrated into one single system. The AMAG Symmetry System 8 (aka the Security Management System or SMS) provides the software interfaces which allow the separate systems to integrate and function as one. The integration of other systems into the standard SMS provides the following benefits:

- A single historical database
- A single interface for monitoring centerstaff
- The ability to automatically and immediately pre-position and display cameras in response to particular events.

STANDARD SECURITY SYSTEMS			
SYSTEM	ABBREVIATION	BRAND	NOTES
Physical Access Control System	PACS	Symmetry Access Control (AMAG)	
Video Management System	VMS	CompleteView (Salient)	<i>AMAG version with integration to Symmetry</i>
Intrusion Detection System	IDS	Symmetry Intrusion Management (AMAG)	
Emergency Phones & Intercoms	E-PHONE	Stentofon Alphacom XE	<i>With integration to Symmetry (Intercom Management Module)</i>

Table 1.0.1a: Standard Security Systems

LEGACY SECURITY SYSTEMS / EQUIPMENT			
SYSTEM	ABBREVIATION	BRAND	NOTES
Video Management System	VMS	AMAG Symmetry Video	
Intrusion Detection System	IDS	DMP XR 500 Series	<i>Original IDS implementations were done with DMP Panels integrated to Symmetry.</i>
Emergency Phones & Intercoms	E-PHONE	Various Phones	<i>Various IP and analog phones exist.</i>

Table 1.0.1b: Legacy Security Systems/Equipment

## 1.02 SUPERVISING STATIONS

Metro Campus Police and Security Services (CPSS) Dispatch serves as a Proprietary Supervising Station for all Tri-C fire and security alarm systems.

Exception – The systems at Corporate College East and Corporate College West which are monitored by Commercial Monitoring Companies.

## 1.03 IMPLEMENTATION STATUS

All College sites use the Standard SMS except as follows:

### **CORPORATE COLLEGE EAST (CCE):**

- The majority of the building security is connected to a: Galaxy PACS System and a NAPCO IDS System. Newer Access Control Doors use the AMAG system.

### **CORPORATE COLLEGE WEST (CCW):**

- The majority of the building security is connected to an ADT Focus System. Newer Access Control Doors use the AMAG system.

**COLLEGE WIDE:**

- Legacy, standalone, BEST electronic door locks using card or pin code technology. These locks are to be replaced and updated whenever possible.

1.04 SYSTEM OVERVIEW

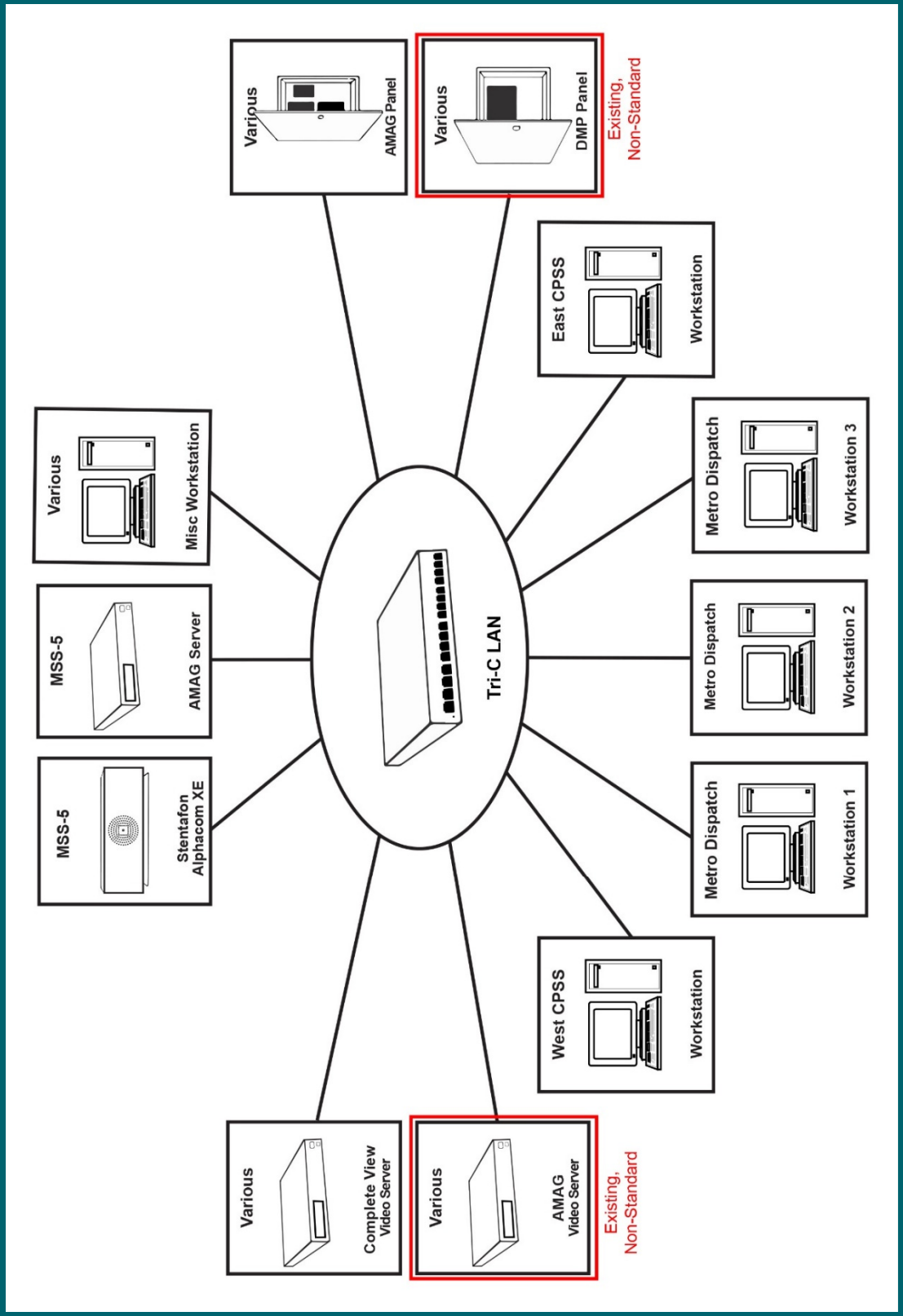

Figure 1.04: System Overview



---

## Part 2 - General Requirements



## 2.01 GENERAL DESIGN REQUIREMENTS

- A. New systems and extensions of existing systems shall be in accordance with this document.
- B. The designer shall be experienced in the design of integrated security systems.
- C. The design must include all customary requirements for a professional security design using this document as a guide. Common technical design elements that should be included (but are not limited to):
  - 1. Hardware
  - 2. Cabling requirements (Quantity and Type)
  - 3. Necessary hardware or software updates, upgrades, licenses, etc., related to the Head End equipment, so that new devices will operate in a manner consistent with existing devices.
  - 4. Necessary configuration / programming so that new devices will operate in a manner consistent with existing devices (or as required by this document.) The Contractor shall be responsible for hardware configuration, programming of new graphical maps, access levels, time periods, groups, alarms, etc.

*NOTE: CPSS will program cardholder records.*

## 2.02 SPECIFIC DESIGN REQUIREMENTS

- A. Security drawings shall include Architectural door numbers for every security door.
- B. All devices on drawings shall be numbered individually and listed in a table which is also included on the drawings.
- C. Security camera design submittals shall include:
  - 1. A graphical depiction of coverage area. Graphical floor plan overlays or 3D renderings are acceptable.
  - 2. Approximate pixel-on-target calculations (included in table) for the desired view.

## 2.03 COORDINATION

- A. Network Capacity
  - 1. The College's ITS Department shall be consulted whenever IP based control panels, cameras, computer equipment, etc. are to be added to system. This consultation shall take place before quotes or estimates are provided so that any required network or computer hardware upgrade can be determined if needed.

## 2.04 ALLOWANCES

### A. College Standard Computers

1. Computers, including servers, shall be Tri-C standard models. Coordinate with Tri-C Capital and Construction Office for allowances or owner direct purchase of equipment. General budget amounts are as follows:
  - a. \$12,000 for each server
  - b. \$3,000 for each standard Workstation

## 2.05 STANDARDS

- A. Cuyahoga Community College Physical Security Systems Design Assistance Manual
- B. Cuyahoga Community College Door Hardware Design Assistance Manual
- C. Cuyahoga Community College Fire Alarm Systems Design Assistance Manual

## 2.06 APPROVED SUPPLIERS

- A. Convergent
- B. US Communications
- C. Premise Solutions



---

## Part 3 - Physical Access Control Systems (PACS)

### 3.01 PHYSICAL ACCESS CONTROL SYSTEM (PACS) – GENERAL

- A. The PACS shall be an extension of the existing AMAG Symmetry System.
- B. Coordinate with CPSS for locations where local locking capability is required.

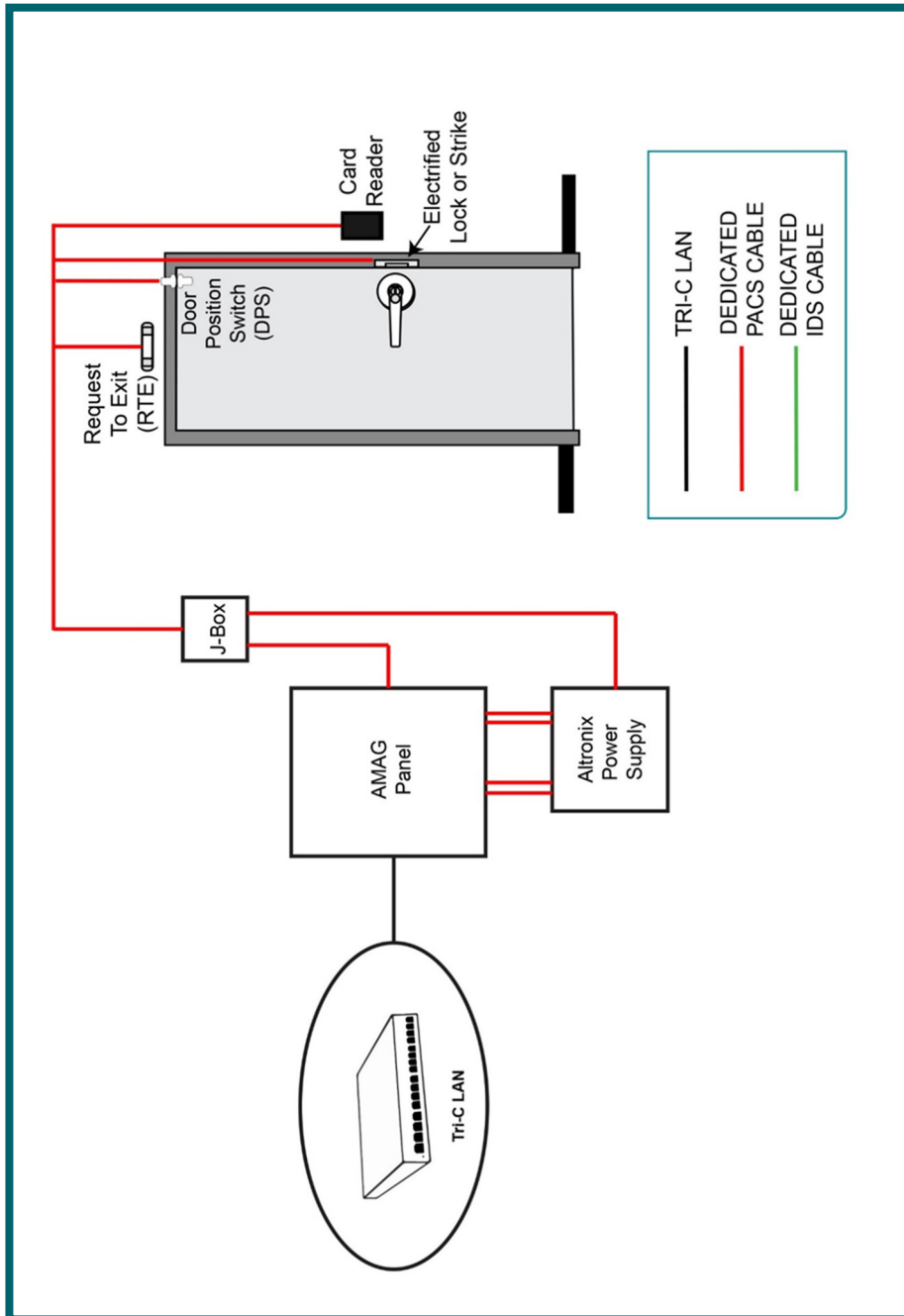

Figure 3.01: System Overview

### 3.02 PHYSICAL ACCESS CONTROL SYSTEM – WHERE REQUIRED

- A. Electronic access controls will be placed in conjunction with the Threat Vulnerability Assessment (TVA); at a minimum, however, they must be placed in the following locations:
  - 1. Perimeter Doors
    - a. On outside entrances to facilities that are normally unlocked during business hours.
    - b. Doors that have been designated “Emergency Exit Only” shall have a status contact and siren installed that are connected to the EAC system to monitor for propped- open or forced-open doors.
    - c. At transition points between buildings.
  - 2. Property Protection
    - a. Inside the building where equipment with a high (or perceived as high) value is stored or permanently set up for use. Examples include but are not limited to:
      - 1) Distance learning labs
      - 2) Computer labs
      - 3) Music recording equipment
      - 4) Video or multimedia production equipment
      - 5) Stage lighting, etc.
  - 3. Cash Handling
    - a. Inside the building at bursars, treasury, or bank service offices.
  - 4. Miscellaneous
    - a. ITS rooms and closets
    - b. Any door where it would be required that keys be issued to students.
    - c. Mailroom doors (including faculty mailrooms.)

### 3.03 EQUIPMENT REQUIREMENTS

REQUIRED PACS CONTROL EQUIPMENT			
EQUIPMENT	MANUFACTURER	MODEL	NOTES
PACS Control Panel & Door Power Supply (4-6 Doors)	AMAG	M2150 8DBC (or 8DC if DBC already in room)	<i>Provide 2 spare reader points for each 8 door controller.</i>
	Altronix	eFlow 104NX with ACM8CB	<i>Or pre-approved equal by Securitron or AlarmSaf.</i>
PACS Control Panel & Door Power Supply (1-3 Doors)	AMAG	M2150 4DBC (or 4DC if DBC already in room)	<i>Provide 1 spare reader point for each 4 door controller.</i>
	Altronix	eFlow 4N with ACM4CB	<i>Or pre-approved equal by Securitron or AlarmSaf.</i>

Figure 3.03a: Required PACS Control Equipment

REQUIRED PACS READERS			
EQUIPMENT	MANUFACTURER	MODEL	NOTES
Reader - Standard, Wall Mount	HID	R40	920PTNNEK00451
Reader - Standard, Mullion Mount	HID	R15	910PTNNEK00451
Reader with Keypad	HID	RPK40	921PTNNEK00451
Reader - Arm / Disarm	AMAG	Javelin S880-KP	

Figure 3.03b: Required PACS Readers

REQUIRED PACS SENSORS, SWITCHES, AND BUTTONS			
EQUIPMENT	MANUFACTURER	MODEL	NOTES
Request To Exit Motion Sensor	Honeywell	IS 310	<i>Honeywell IS 310</i>
	Bosch	Ds160	<i>Bosch Ds160</i>
	Takex	PS-520E	<i>Takex PS-520E</i>
Door Position Switch	Interlogix	Magnetic Switch appropriate for application	<i>Typical: Concealed 3/4" to match door color.  Armored w/appropriate configuration for overhead doors.</i>
	Nascom		
	Ademco		
Emergency Exit Button (Wall Mounted)	Dortronics	W5286-P23DA	<i>NOTE: Only for use with magnetically locked egress doors.</i>
	Security Door Controls	SDC 423PU	
	Securitron	EEB2	
Emergency Exit Button (Frame Mounted)	Dortronics	N5286-P23DA	<i>NOTE: Only for use with magnetically locked egress doors.</i>
	Security Door Controls	SDC 413PU	
	Securitron	EEB3N	

Figure 3.03c: Required PACS Sensors, Switches, and Buttons





---

## Part 4 - CCTV System

#### 4.01 GENERAL

A. The CCTV System shall be an extension of the AMAG Symmetry CompleteView System.

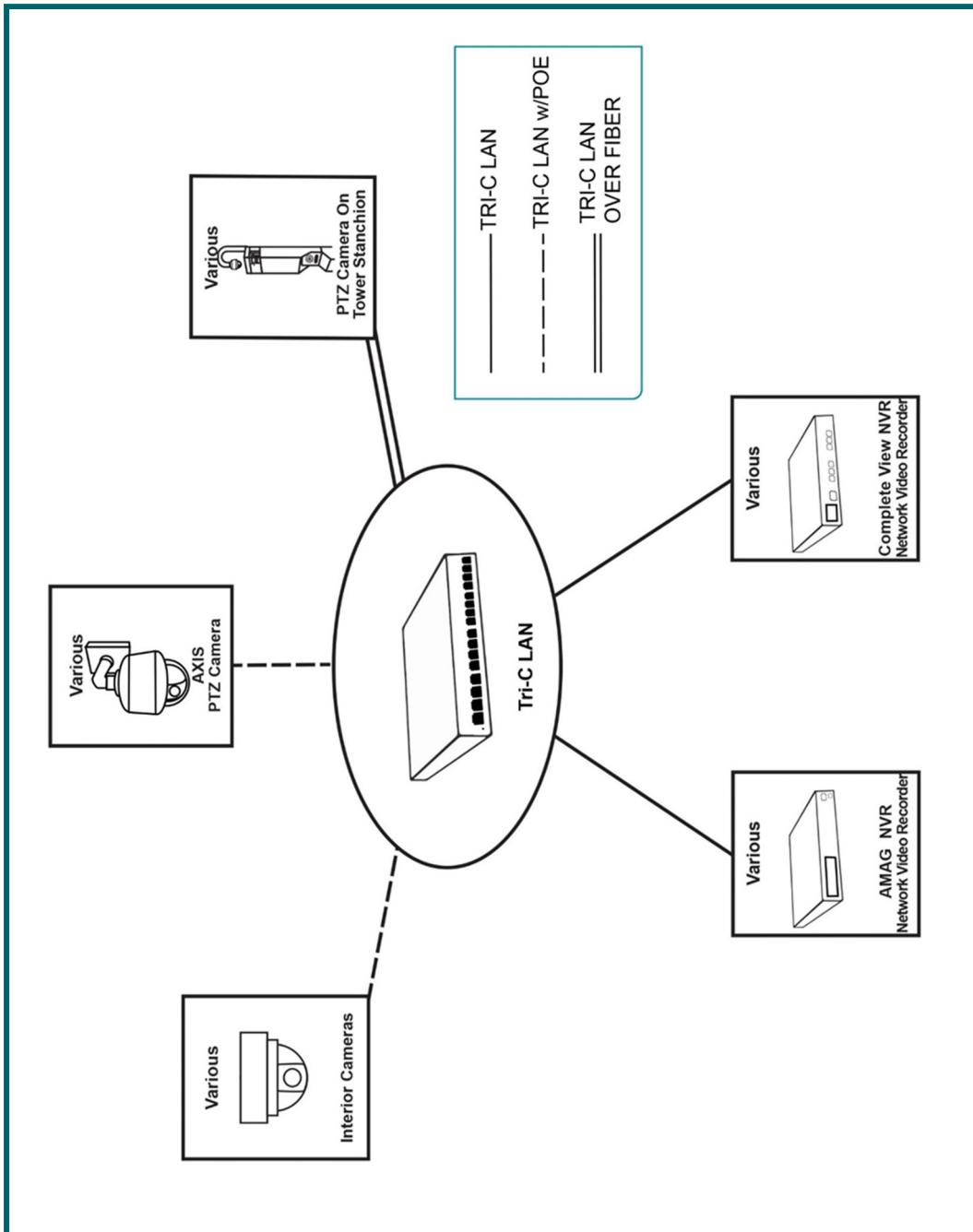

Figure 4.01: CCTV System Overview

B. Terminology and requirements related to Level of Detail (LOD) or Pixels on Target shall be in accordance with BSIA Publication 109 (EN 50132-7).

C. ITS Coordination

1. Coordinate with ITS to determine existing Recording Server capacity and location.

#### D. CPSS Coordination

1. Coordinate recording rates, image quality, tours, sequences, field of view, etc. with CPSS.

### 4.02 CCTV SYSTEM – WHERE REQUIRED

Cameras shall be placed in conjunction with the Threat Vulnerability Assessment (TVA); at a minimum, however, cameras shall be placed in the following locations:

#### A. General:

1. Entrances: Inside the building displaying each entrance or exit of building.
  - a. Typical field of view – a zone that is 2 feet above, 4 feet on each side, and 8 feet in front of the doorway.
  - b. Typical Level of Detail – Identification (76 H-PPF)
2. Corridors: Inside the building displaying a general overview of main corridors.
  - b. Typical field of view – Overview, little or no ceiling, walls minimal or centered.
  - c. Typical Level of Detail – Observation (19 H-PPF)
3. Transitional Points: Inside the building displaying transitional points between floors (elevator, stairs). Inside the building displaying public to private transition points.
  - c. Typical field of view – a zone that is 2 feet above, 4 feet on each side, and 8 to 12 feet in front of the opening.
  - d. Typical Level of Detail – Recognition (38 H-PPF). Note: If other entrances to either area do not have Identification Level coverage, provide it at the transition point.

#### B. Points of Interest

1. Cash Transactions: Inside the building displaying locations where cash is exchanged (cash registers, ATMs). Vending machines shall not fall under this requirement unless identified during the TVA as an area requiring cameras.
  - a. Typical field of view – a zone that is 2 feet higher than the highest point of interest, 4 feet on each side, and 8 feet in front of the area.
  - b. Typical Level of Detail – Identification (76 H-PPF) or Strong Identification (303 H-PPF) depending on situation.

#### C. Alarm Sensors and Switches: Inside the building at each security or duress alarm point.

1. Typical field of view – Alarm point and surrounding area.
2. Typical Level of Detail – Recognition (38 H-PPF) or Identification (76 H-PPF) depending on the situation.

#### D. Access Controlled Doors

1. Typical field of view – Door and surrounding area.
2. Typical Level of Detail – Typical Level of Detail – Observation (19 H-PPF) or Recognition (38 H-PPF) depending on situation.

#### E. Exterior

1. Walkways and Parking: Outside the building to provide coverage of walkways and parking areas associated with the building.
  - a. Typical field of view – Areas as listed.
  - b. Typical Level of Detail – Observation (19 H-PPF)
2. E-Phones: A high resolution, fixed camera shall be provided to view each emergency/blue light phone location.
  - a. Typical field of view – Areas as listed.
  - b. Typical Level of Detail – Observation (19 H-PPF)

### 4.03 EQUIPMENT REQUIREMENTS

Security camera equipment is discontinued and replaced with new equipment more often than any other security equipment. Basis of design model numbers would quickly become obsolete and will not be listed. The following requirements apply to new CCTV system equipment:

#### A. Requirements for All Cameras

1. Equipment must be listed by Salient as being compatible with the installed version of AMAG Symmetry CompleteView.
2. Vandal resistant enclosure
3. Remote focus capability
4. Automatic Iris
5. Capable of using onboard, third party, analytics applications
6. Audio input or built in microphone
7. Approved Manufacturers where specific model meets the listed requirements:
  - a. Samsung
  - b. Axis
  - c. Sony

B. Interior Cameras

1. Frame Rate – Min 30 frames per second at highest resolution.
2. Shutter Speed - 1.4s or less to 1/8,000 of a second or faster.
3. Focal range - 3mm to 8mm or greater

C. Exterior Cameras

1. IP66 or NEMA 4X rated
2. Focal range – Varifocal as required for the intended view.
3. “Wide Dynamic Range” greater than 100 decibels (dB).
4. Day / Night Mode using a removable IR-cut filter
5. Minimum light and shutter speed requirements: 0.08 lux at  $\frac{1}{2}$  sec shutter (Color), 0.30 lux at  $\frac{1}{60}$  sec shutter (B/W), 0.013 lux at  $\frac{1}{2}$  sec shutter (B/W)

CAMERA REQUIREMENTS (BY TYPE)				
TYPE	ABBREV	MIN. FOCAL LENGTH/FOV	MIN. RES.	REQUIREMENTS
Interior, Standard Resolution	INT-S	3mm-8mm	1080p	<i>Not for use in areas where backlighting will occur.</i>
Interior, High Resolution	INT-H	3mm-8mm	3MP	<i>Use for backlit scenes and areas where higher resolution is needed. "Wide Dynamic Range" greater than 100 decibels (dB).</i>
Interior, Wide Angle*	INT-W	130-degree or greater field of view	1080p	
Interior, 360 Degree*	360		5MP	<i>360-degree fov with de-warping plugin compatible with Completeview software.</i>
Exterior, High Resolution	HRES-EXT	3mm-12mm	5MP	<i>"Wide Dynamic Range" greater than 100 decibels (dB).</i>
Exterior, Pan-Tilt-Zoom	PTZ	Minimum optical zoom capability of 22X.	1080p	<i>Rated for continuous duty, Image stabilization, Privacy masking / Window Blanking, "Wide Dynamic Range" greater than 100 decibels (dB).</i>

Table 4.03: CCTV Camera Types

\*Requires CPS approval for use on a case-by-case basis.

---

## Part 5 - Intrusion Detection System (IDS)



5.01 IDS SYSTEM – GENERAL

- A. New Intrusion detection devices shall be installed as an extension to the AMAG Symmetry Intrusion System using AMAG control hardware.

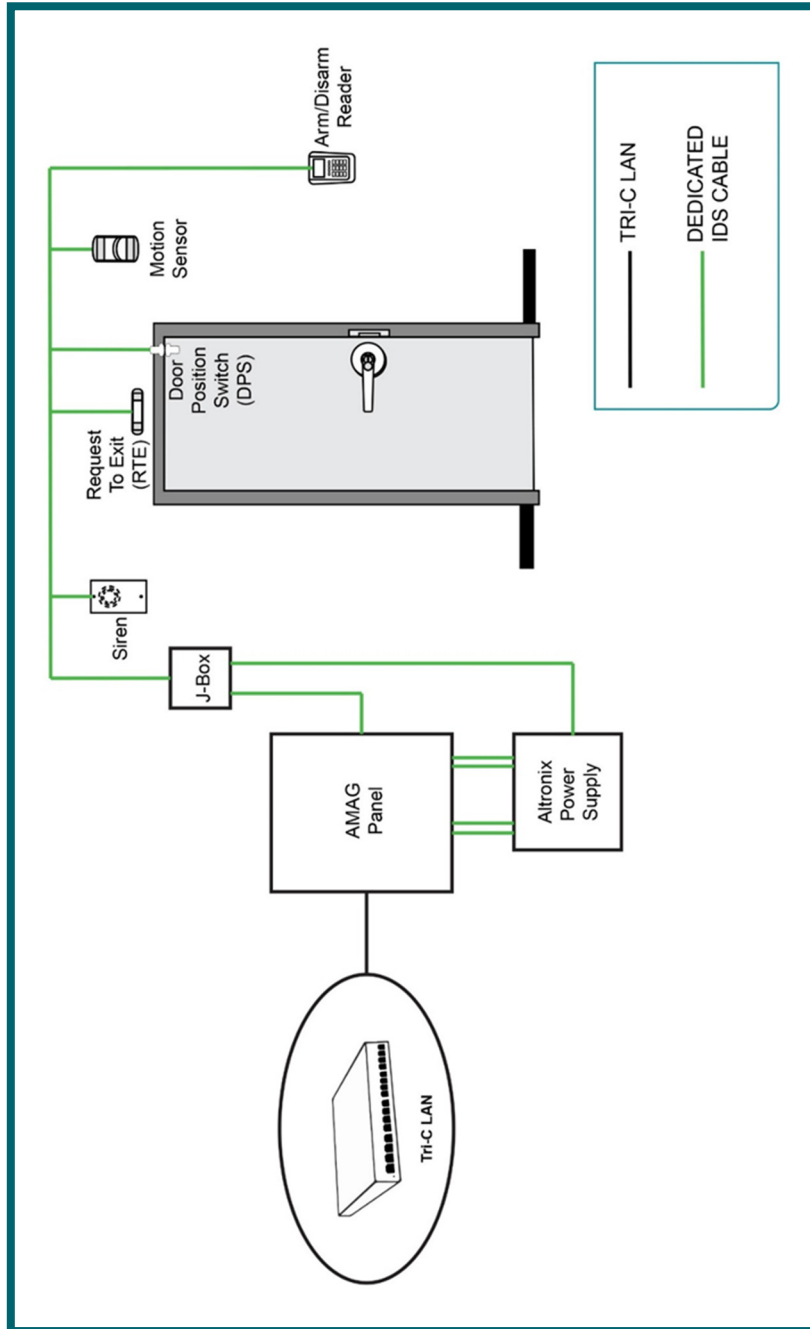

Figure 5.01: IDS System Overview

## 5.02 IDS – WHERE REQUIRED

### A. General

1. Exterior Doors: All outside doors should have a Door Position Switch (DPS) and Request-To-Exit (RTE) device. Latch-bolt monitors should be used where detection of door propping is critical.
2. Corridors: Provide motion detection of main corridors and outside of public restrooms.
3. Transitional Points: Buildings should be designed so that sections may be closed when not in use. Zone areas appropriately and provide means for arming / disarming at entrances to areas.

### B. Points of Interest

1. Inside the building where equipment with a high (or perceived as high) value is stored or permanently set up for use. Examples include but are not limited to:
  - a. Distance learning labs
  - b. Computer labs
  - c. Music recording equipment
  - d. Video or multimedia production equipment
  - e. Stage lighting, etc.
2. Cash Handling and Storage
  - a. Inside the building at bursars, treasury, or bank service offices. An outer perimeter should be created which allows early detection. A second, inner perimeter, should be created at the point where the money is accessed.

## 5.03 IDS – OPERATION

### A. Operation – Public Areas

1. Auto-Arm Schedule: Devices in public areas shall be controlled by an auto arm/disarm schedule.
2. Device Grouping: Devices shall be grouped to facilitate overriding the arm/disarm of logical areas by CPSS Dispatch.
3. Coordinate schedule and grouping of devices with CPSS.

### B. Operation – Controlled Areas

1. Department Suites and Labs: Department suites, labs, and other controlled areas shall be configured as independent partitions of the main building. This will allow the public areas of the main building to be in use while maintaining security of unoccupied controlled areas.

2. Arm/Disarm Reader: Arm/Disarm shall be executing using an AMAG Javelin reader outside of the controlled area.
3. Auto-Arm Schedule: An auto-arm time shall be configured, as a backup arming means, for each controlled area.

#### 5.04 EQUIPMENT REQUIREMENTS

REQUIRED IDS EQUIPMENT			
EQUIPMENT	MANUFACTURER	MODEL	NOTES
Control Panel	AMAG	AC 24/4*	See PACS Equipment Table for panel details.
Aux Power Supply	Altronix	eFlow 4N8	Or equal model by Securitron or AlarmSaf
Motion Detector	Bosch	ISC-PPR1-WA16x	Or approved equal.
Door Position Sensor (DPS)	Interlogix	Magnetic switch appropriate for application. Consult the publication "Intrusion Sensor Application Notebook" by GE Security for best-practices.	
	Nascom		
	Ademco		

Table 5.04: IDS Equipment Requirements

---

## Part 6 - Duress Alarms

## 6.01 DURESS ALARMS – GENERAL

- A. All Duress Alarm devices shall be connected to the AMAG System.

## 6.02 DURESS ALARMS – WHERE REQUIRED

### A. General

1. Duress Alarms shall be used at locations where episodes of Workplace Violence (WPV) are most likely to occur.
2. Duress Alarm Devices shall be located as listed in this document and as determined by CPSS based on the site-specific risk.
3. Where a reception desk or transaction counter with multiple workstations is protected with Duress Alarm Devices, each work station shall be equipped with one of the devices.

### B. Senior Administrative Areas

1. Provide a Duress Alarm Device at the reception desk and at the secretary's desk.

## 6.03 DURESS ALARMS – EQUIPMENT REQUIREMENTS

### A. General

1. Wireless devices shall not be used unless approved by CPSS on a case-by-case basis.
2. For resolution of false alarm issues, each device shall be installed as a separate identifiable input point.
3. Devices shall be supervised and shall report trouble if removed.
4. No audible alarm shall sound at the location of the Duress Alarm Device.

### B. Device Selection

1. The type of device shall be selected so that its operation will not be obvious to the aggressive party.
2. A holdup button is the standard device that shall be used (Basis of Design - Potter HUSD-15BM)
3. Bill trap devices may be used for cash drawers.
4. Foot switches may be used, with the approval of CPSS, if it is determined that a holdup button or bill trap would not meet the needs of that specific location.

### C. Installation Methods

1. The device shall be located so that it may not be observed by the public.
2. The activating portion of the device shall be installed within four feet of the workstation and accessible to be operated from the normal work position of the individual responsible for utilization of the device. Normally, one device per workstation will be used.
3. The device shall be installed in a manner to prevent accidental operation by the person utilizing the work area. Activation of the device shall require a positive and intentional action.
4. All wire under the desk shall be in metallic wire mold to prevent damage.



---

## Part 7 - Emergency Phones



## 7.01 EMERGENCY PHONES- GENERAL

- A. This section covers Emergency “Blue Light” Phones (E-PHONES) and Code required Emergency Communication Systems (ECS) devices.

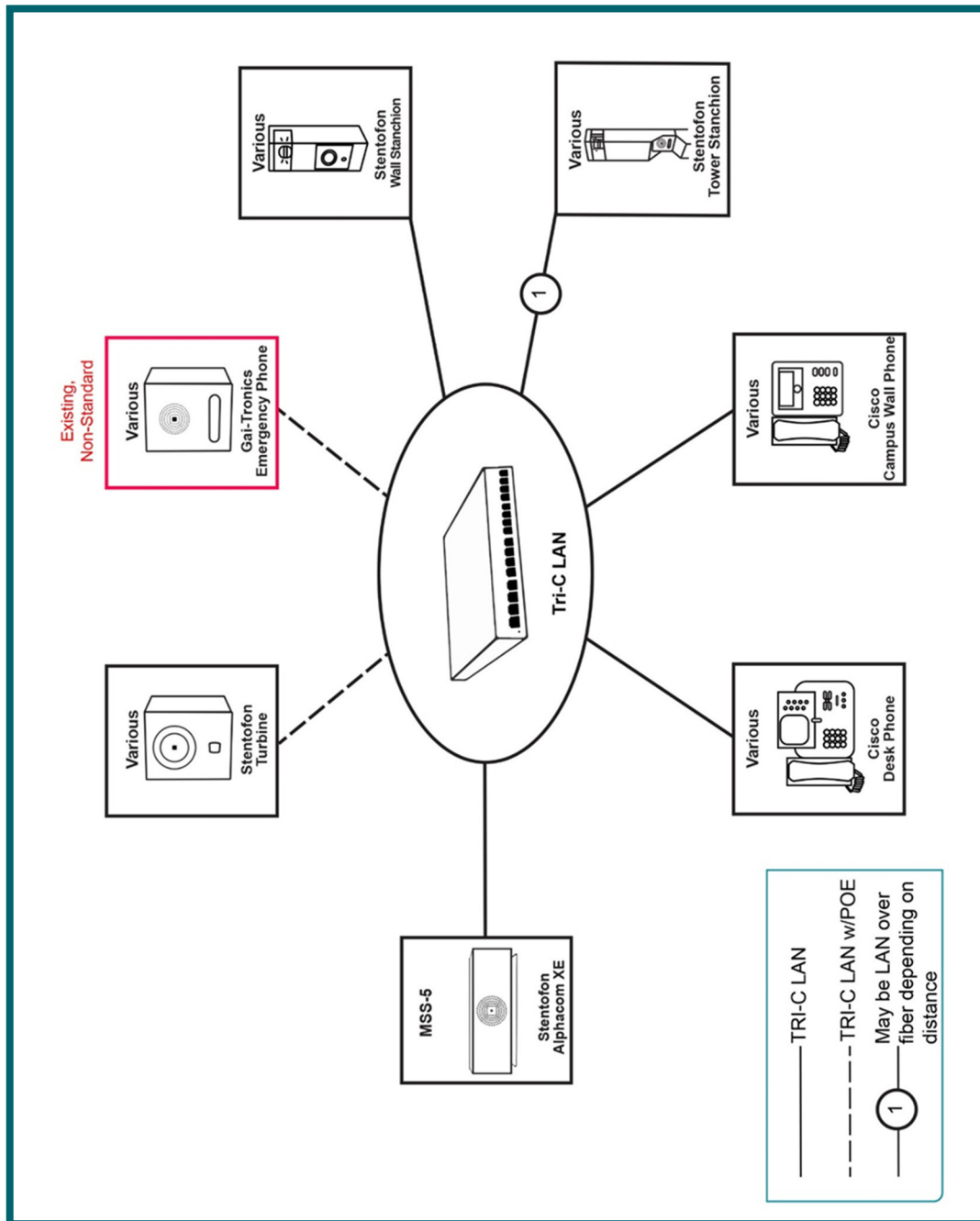

Figure 7.01: E-Phone System Overview

B. ECS

1. ECS devices shall be an extension of the College phone system and shall be programmed to automatically call the CPSS Dispatch.

C. E-PHONES

1. E-PHONES shall be an extension of the Stentofon System which is integrated to the AMAG Symmetry System.
2. E-PHONES will be placed in conjunction with the site-specific Threat Vulnerability Assessment (TVA) and at Standardized Locations based on previous Assessments.
3. Emergency Phones shall be an extension of the existing Stentafoon Alphacom XE System - integrated with the AMAG Symmetry System.

## 7.02 WHERE REQUIRED

- A. ECS devices will be placed as required by Code (typically in elevator lobbies)
- B. New E-PHONES are required for exterior campus areas. Interior devices are not normally required unless needed to mitigate a risk identified by the security assessment. Typical Locations:
  1. Near main building entrances: Device shall be placed to maximize visibility from as many approaching directions as possible. An integral camera (PTZ) shall be included if it provides a view of exterior walkways or other areas of interest.
  2. Parking lots: Locate at walkway leading from parking lot to building. An integral camera (PTZ) shall be included.
  3. High Risk Areas / Areas of Isolation: In areas of higher risk as identified by the security assessment.

## 7.03 EPHONES – EQUIPMENT REQUIREMENTS

- A. Tower Stanchion shall be blue in color and labeled “Emergency” on all 4 sides. Wall mounted stanchions may be used where applicable.
- B. Include surge protection devices for all circuits between the building and the device.
- C. 120-volt power shall be from a dedicated breaker with a (blue painted) breaker lock.

## 7.04 INSTALLATION

- A. Device shall be installed adjacent to the walking path and shall be accessible as required by the Ohio Building Code.
- B. Poles or stanchions shall not intrude onto the walking path causing issues with snow removal.

REQUIRED EPHONE EQUIPMENT			
EQUIPMENT	MANUFACTURER	MODEL	NOTES
Tower Stanchion	Stentafon	1000160000	<i>Basis of design model. Other devices similar in quality and appearance may be acceptable.</i>
Wall Stanchion	Stentafon	1000160200	
Station	Stentafon	TCIS-2	

Table 7.03: EPHONE Equipment Requirements

---

## Part 8 - Locks

8.01 LOCKS AND KEYS – GENERAL

A. The Tri-C “Door Hardware Design Assistance Manual” document should be referenced and is available in the Capital and Construction Department.

8.02 ELECTRIC LOCKS– TYPES

Note: See Appendix A for more information for each door type.

SINGLE DOORS - ELECTRIC LOCK DESIGN GUIDE					<b>NOT FIRE RATED</b>
<i>For a door with these specs:</i>			<i>Use this type of lock:</i>		
DOOR TYPE	EXIT DEVICE	ADA DOOR?	HARDWARE	DOOR TYPICAL	NOTES
Single	Lever	N	Electric Mortise Lockset	EL-LOCK	
Single	Rim Panic	N	Electrified Trim	EL-TRM	
Single	Lever or Rim Panic	Y	Electric Strike	EL-STR	

Table 8.02a

SINGLE DOORS - ELECTRIC LOCK DESIGN GUIDE

**FIRE  
RATED**

<i>For a door with these specs:</i>			<i>Use this type of lock:</i>		
DOOR TYPE	EXIT DEVICE	ADA DOOR	HARDWARE	DOOR TYPICAL	NOTES
Single	Lever	N	Electric Lockset	EL-LOCK	
Single	Rim Panic	N	Electrified Trim	EL-TRM	
Single	Rim Panic	Y	* Electrified Trim & Electric Strike	EL-STR/TRM	

*\* Fire alarm designer must add smoke detection which disables strike and operator.*

*General Note: Stairwell doors require a switch at the fire department response point, which unlocks all stairwell doors, allowing reentry from the stairwell to the floor.*

Table 8.02b

ELECTRIC LOCK DESIGN GUIDE - DOUBLE DOORS

**NOT FIRE  
RATED**

**W/ CENTER MULLION (STANDARD)**

*For a door with these specs:*

*Use this type of lock:*

DOOR TYPE	EXIT DEVICE	ADA DOOR	LEFT LEAF	RIGHT LEAF	DOOR TYPICAL	NOTES
Double	Rim Panic	N	No outside trim (Typical*)	Electrified Trim	EL2-TRM	
Double	Rim Panic	Y**	Electric Strike	Electric Strike	EL2-STR	

**NO CENTER MULLION (REQUIRES APPROVAL)**

*For a door with these specs:*

*Use this type of lock:*

Double	Vert Rod Panic	N	No outside trim (Typical*)	Electrified Trim	EL2-TRM	
Double	Vert Rod Panic	Y**	Electric Trim	Electric Latch Retraction Panic	EL2-TRM / PAN	<i>Quiet / or motorized latch retraction.</i>
Double	Lever	N	Manual Bolt (s)	Electric Mortise Lockset	EL2-LOCK	<i>One leaf fixed with manual bolts</i>

\* For main entrances-both leaves should have electric locking w/ outside trim.

\*\* Standard is to control a single 36" leaf, with a door operator, unless "site specific" needs require more. Left leaf should have electric locking w/outside trim to encourage manual opening of door.

Table 8.02c

ELECTRIC LOCK DESIGN GUIDE - DOUBLE DOORS

**FIRE  
RATED**

W/ CENTER MULLION (STANDARD)

*For a door with these specs:*

*Use this type of lock:*

DOOR TYPE	EXIT DEVICE	ADA DOOR	LEFT LEAF	RIGHT LEAF	DOOR TYPICAL	NOTES
Double	Rim Panic	N	No outside trim (Typical*)	Electrified Trim	EL2-TRM	
Double	Rim Panic	Y**	Electric Trim	Electrified Trim & Elec Strike ***	EL2-TRM / STR	

NO CENTER MULLION (REQUIRES APPROVAL)

*For a door with these specs:*

*Use this type of lock:*

Double	Vert Rod Panic	N	No outside trim (Typical*)	Electric Trim	EL2-TRM	
Double	Vert Rod Panic	Y**	Electric Trim	Electric Latch Retraction Panic ***	EL2-TRM / PAN	Quiet / or motorized latch retraction.

\* For main entrances-both leaves should have electric locking w/ outside trim.

\*\* Standard is to control a single 36" leaf, with a door operator, unless "site specific" needs require more. Left leaf should have electric locking w/outside trim to encourage manual opening of door.

\*\*\* Fire alarm designer must add smoke detection which disables operator and strike or electric latch retraction panic.

Table 8.02d





**APPENDIX A**  
**SECURITY DOOR**  
**TYPICALS**

**EL-LOCK (TYPICAL)**  
**SINGLE DOOR, ELECTRIFIED LOCKSET**  
**SCALE: NONE**

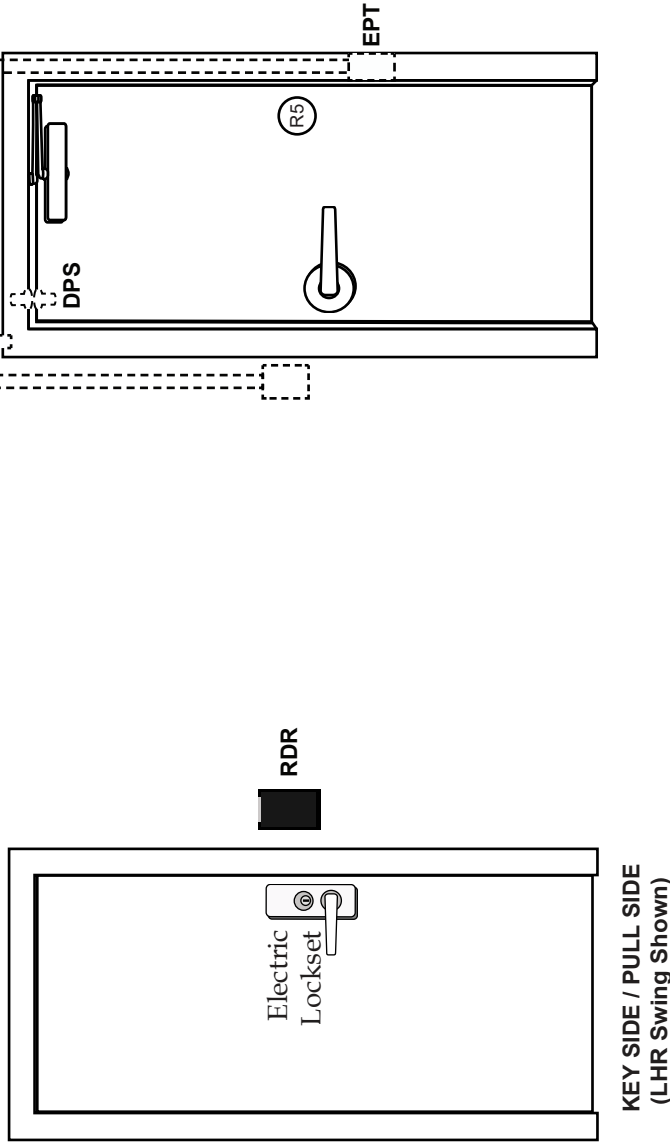

**KEY SIDE / PULL SIDE**  
**(LHR Swing Shown)**

**ROUGH-IN NOTES:**

- R1. Composite Access Control Cable to AMAG Control Panel. Follow the National Electric Code and project specific requirements for conduit and open cabling.
- R2. 4" x 4" service junction box with splices for all circuits. For suspended ceilings mount box above ceiling. For hard ceilings mount device so that there is 4" between top of box and the hard ceiling. For ceilings over 12' coordinate an accessible location with Architect.

**GENERAL NOTES:**

- R3. Door Position Sensor (DPS): 1/2" emt conduit w/cable, concealed in wall, stubbed into door frame.
  - R4. Reader (RDR): 1/2" emt conduit w / cable, concealed in wall, continuous to single gang, flush, back box (48" AFF to top) w/ Reader Spacer.
  - R5. Request-To-Exit (RTE) Switch and Lock: Route cable(s) through frame, through EPT, and door. For filled frames provide 1/2" emt conduit from frame head to EPT.
- GENERAL NOTES:**
1. All required devices and their typical mounting locations are shown here. Readers (RDR) are also shown on the floor plan to indicate the specific location where the RDR shall be installed.
  2. For doors requiring an audible alarm provide the following - in addition to the devices required for the door type.

**EL-LOCK2 (TYPICAL)**  
**DOUBLE DOORS, ELECTRIC LOCKSET**  
**SCALE: NONE**

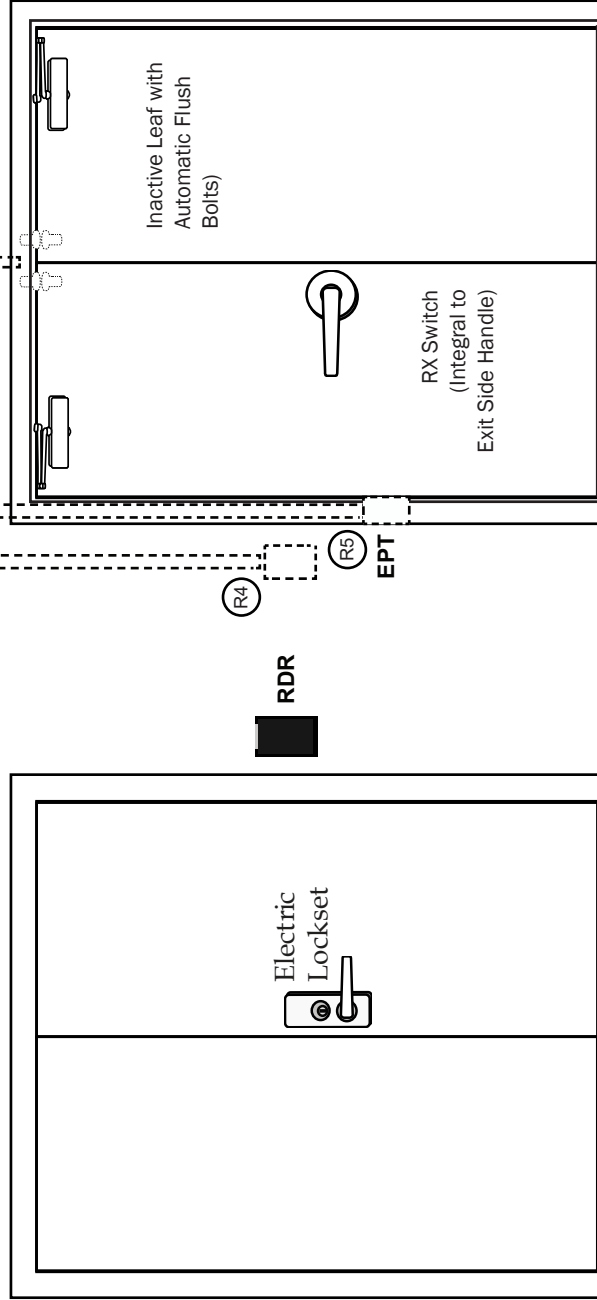

**KEY SIDE / PULL SIDE**  
**(RHRA Swing Shown)**

**ROUGH-IN NOTES:**

- R1. Composite Access Control Cable to AMAG Control Panel. Follow the National Electric Code and project specific requirements for conduit and open cabling.
- R2. 4" x 4" service junction box with splices for all circuits. For suspended ceilings mount box above ceiling. For hard ceilings mount device so that there is 4" between top of box and the hard ceiling. For ceilings over 12' coordinate an accessible location with Architect.
- R3. Door Position Sensors (DPS): 1/2" emt conduit w/cable, concealed in wall, stubbed into door frame.
- R4. Reader (RDR): 1/2" emt conduit w / cable, concealed in wall, continuous to single gang, flush, back box (48" AFF to top) w/ Reader Spacer.
- R5. Request-To-Exit (RTE) Switch and Lock: Route cable(s) through frame, through EPT, and door. For filled frames provide 1/2" emt conduit from frame head to EPT.

**GENERAL NOTES:**

- 1. All required devices and their typical mounting locations are shown here. Readers (RDR) are also shown on the floor plan to indicate the specific location where the RDR shall be installed.
- 2. For doors requiring an audible alarm provide the following - in addition to the devices required for the door type.

**EL-MON (TYPICAL)**  
**SINGLE DOOR, MONITORED**  
**SCALE: NONE**

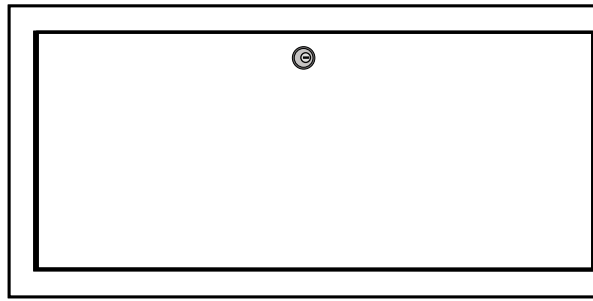

**KEY SIDE / PULL SIDE**  
**(LHR Swing Shown)**

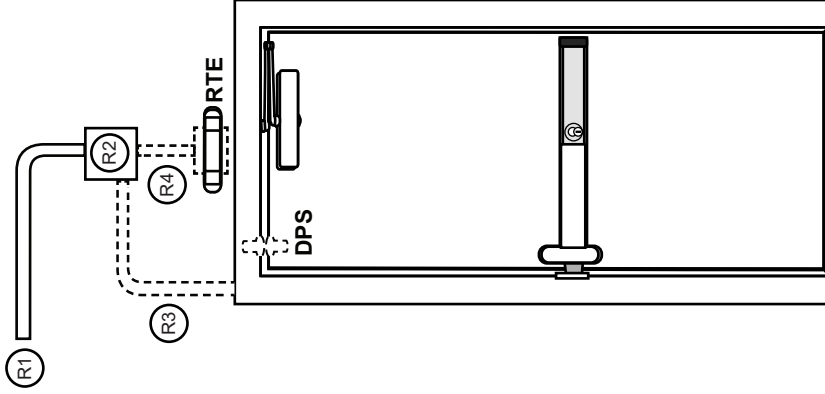

**PUSH SIDE**

**ROUGH-IN NOTES:**

R1. Composite Access Control Cable to AMAG Control Panel. Follow the National Electric Code and project specific requirements for conduit and open cabling.

R2. 4" x 4" service junction box with splices for all circuits. Cut spare cables with 12" slack and coil up in box. For suspended ceilings mount box above ceiling. For hard ceilings mount device so that there is 4" between top of box and the hard ceiling. For ceilings over 12' coordinate an accessible location with Architect.

**GENERAL NOTES:**

1. All required devices and their typical mounting locations are shown here.
2. For doors requiring an audible alarm provide the following - in addition to the devices required for the door type.

R3. Door Position Sensor (DPS): 1/2" emt conduit w/cable, concealed in wall, stubbed into door frame.

R4. Request-To-Exit (RTE) Motion Sensor: 1/2" emt and cable, concealed in wall, continuous to single gang, flush, back box.

**EL-MON-OH (TYPICAL)  
OVERHEAD DOOR, MONITORED  
SCALE: NONE**

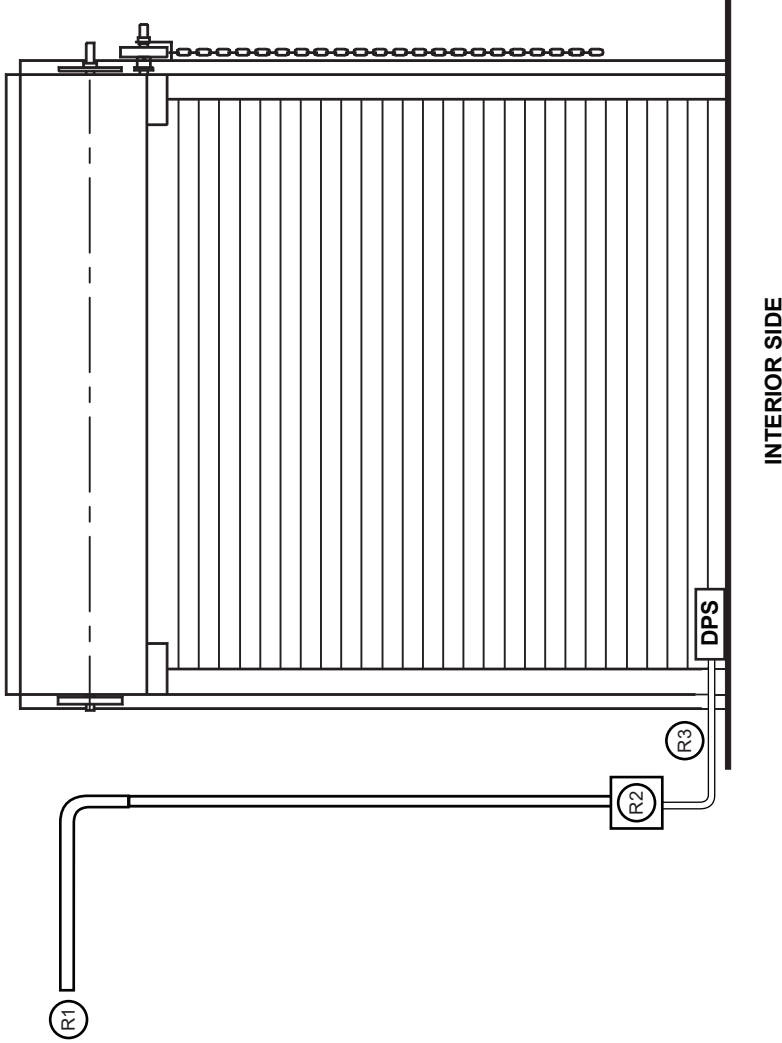

**INTERIOR SIDE**

**ROUGH-IN NOTES:**

- R1. Composite Access Control Cable to AMAG Control Panel. Follow the National Electric Code and project specific requirements for conduit and open cabling.
- R2. 2 gang weather resistant service junction box w/ tamper resistant screws. Run spare cables to this point, cut with 4" slack remaining and coil up in box.
- R3. Armored cable - integral to DPS assembly. Secure to wall / floor every 4" - 6" to prevent damage to cable during use of area around door.

**GENERAL NOTES:**

- 1. All required devices and their typical mounting locations are shown here.
- 2. For doors requiring an audible alarm provide the following - in addition to the devices required for the door type.

**EL-OH (TYPICAL)  
OVERHEAD DOOR, MONITORED  
SCALE: NONE**

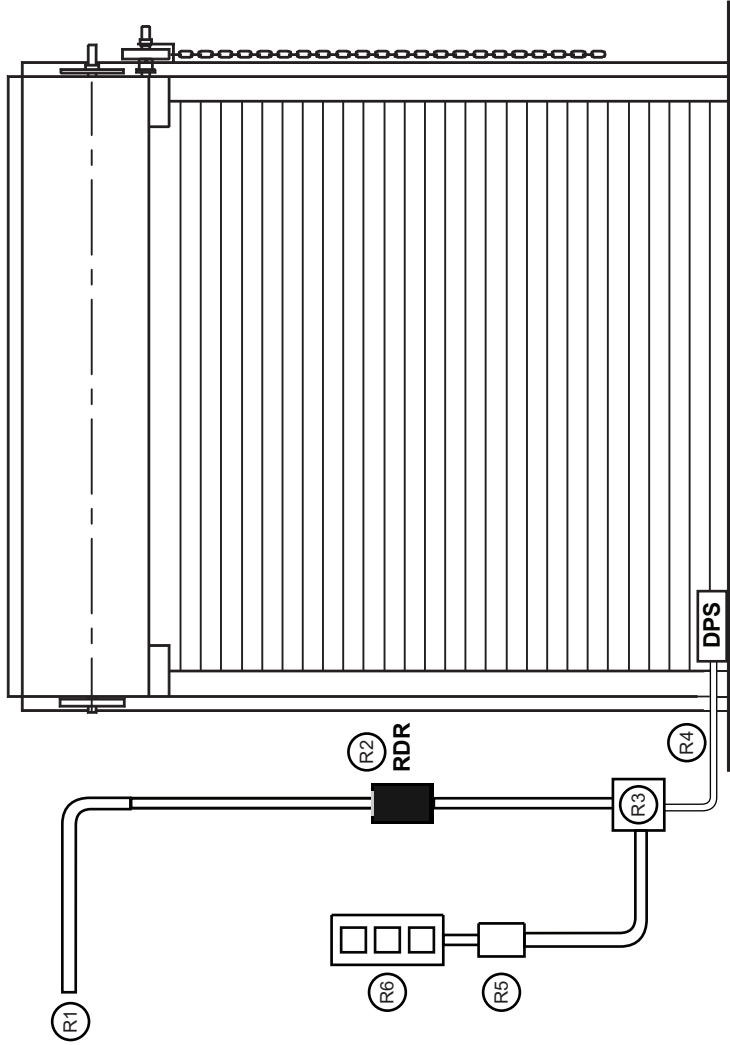

**INTERIOR SIDE**

**ROUGH-IN NOTES:**

- R1. Composite Access Control Cable to AMAG Control Panel. Follow the National Electric Code and project specific requirements for conduit and open cabling.
- R2. Reader (RDR): 1/2" emt conduit w / cable, to single gang, back box (48" AFF to top) w/ Reader Spacer.
- R3. 2 gang weather resistant service junction box w/ tamper resistant screws. Run spare cables to this point, cut with 4" slack remaining and coil up in box.

**GENERAL NOTES:**

- R4. Armored cable - integral to DPS assembly. Secure to wall / floor every 4" - 6" to prevent damage to cable during use of area around door.
  - R5. Single gang junction box with voltage isolation relay. Relay coil shall be 12VDC and contacts shall be rated for voltage and amperage of circuit controlled.
  - R6. Door Control Switch: A valid card read shall enable the Open Button for 60 seconds. The Close and Stop Buttons shall always be enabled.
1. All required devices and their typical mounting locations are shown here.
  2. For doors requiring an audible alarm provide the following - in addition to the devices required for the door type.

**EL-PAN2 (TYPICAL)**  
DOUBLE DOORS, ELECTRIC LATCH RETRACTION PANIC  
SCALE: NONE

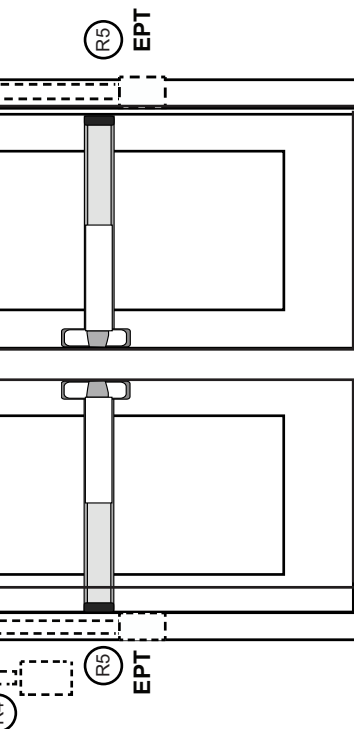
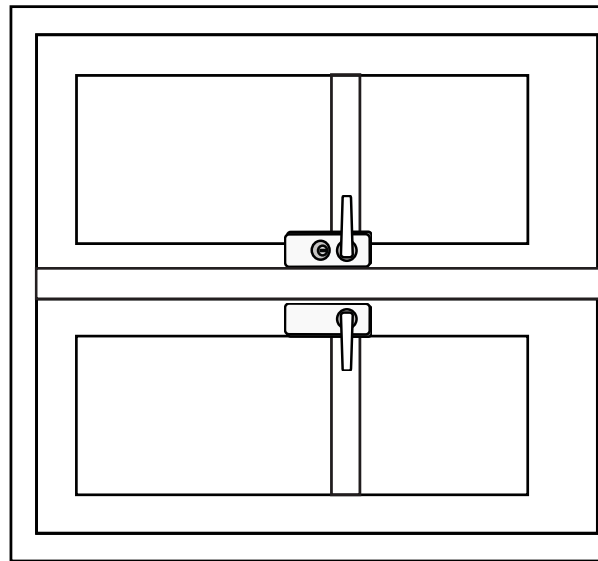

**KEY SIDE / PULL SIDE**  
(RHRA Swing Shown)

**ROUGH-IN NOTES:**

- R1. Composite Access Control Cable to AMAG Control Panel. Follow the National Electric Code and project specific requirements for conduit and open cabling.
- R2. 4" x 4" service junction box with splices for all circuits. For suspended ceilings mount box above ceiling. For hard ceilings mount device so that there is 4" between top of box and the hard ceiling. For ceilings over 12' coordinate an accessible location with Architect.
- R3. Door Position Sensors (DPS): 1/2" emt conduit w/cable, concealed in wall, stubbed into door frame.
- R4. Reader (RDR): 1/2" emt conduit w / cable, concealed in wall, continuous to single gang, flush, back box (48" AFF to top) w/ Reader Spacer.
- R5. Request-To-Exit (RTE) Switches and Locks: Route cable(s) through frame, through EPT, door, and Exit Device. For filled frames provide 1/2" emt conduit from frame head to EPT.

**GENERAL NOTES:**

- 1. All required devices and their typical mounting locations are shown here. Readers (RDR) are also shown on the floor plan to indicate the specific location where the RDR shall be installed.
- 2. For doors requiring an audible alarm provide the following - in addition to the devices required for the door type.



**EL-TRM (TYPICAL)**  
**SINGLE DOOR, ELECTRIFIED TRIM**  
**SCALE: NONE**

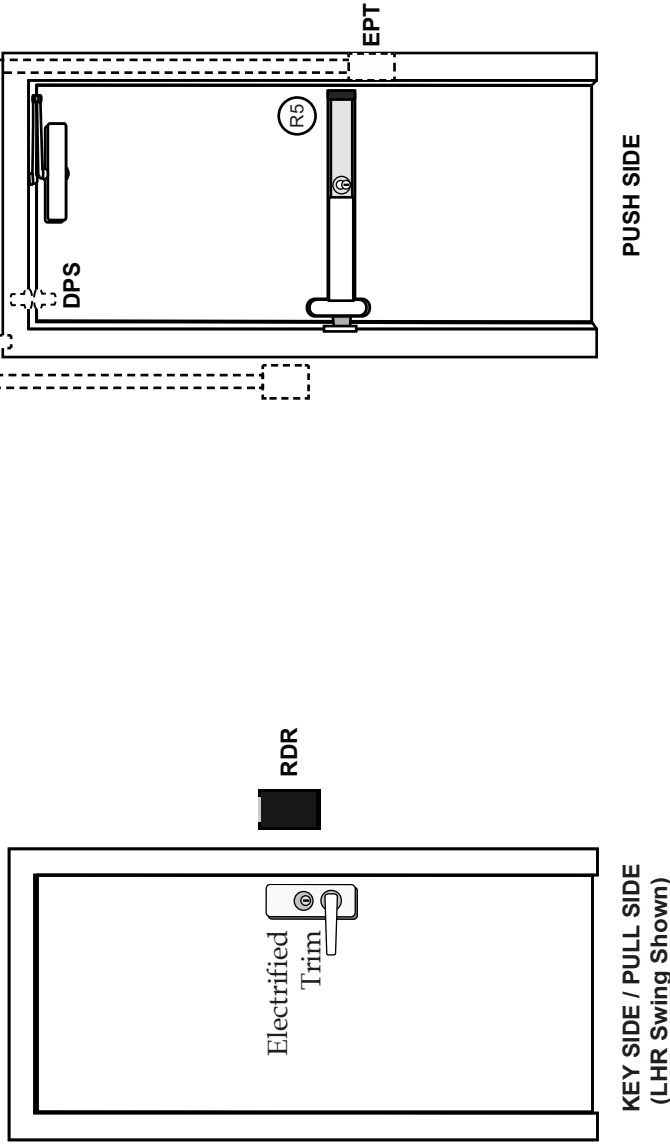

**ROUGH-IN NOTES:**

- R1. Composite Access Control Cable to AMAG Control Panel. Follow the National Electric Code and project specific requirements for conduit and open cabling.
- R2. 4" x 4" service junction box with splices for all circuits. For suspended ceilings mount box above ceiling. For hard ceilings mount device so that there is 4" between top of box and the hard ceiling. For ceilings over 12' coordinate an accessible location with Architect.

**GENERAL NOTES:**

- R3. Door Position Sensor (DPS): 1/2" emt conduit w/cable, concealed in wall, stubbed into door frame.
  - R4. Reader (RDR): 1/2" emt conduit w / cable, concealed in wall, continuous to single gang, flush, back box (48" AFF to top) w/ Reader Spacer.
  - R5. Request-To-Exit (RTE) Switch and Lock: Route cable(s) through frame, through EPT, door, and Exit Device. For filled frames provide 1/2" emt conduit from frame head to EPT.
1. All required devices and their typical mounting locations are shown here. Readers (RDR) are also shown on the floor plan to indicate the specific location where the RDR shall be installed.
2. For doors requiring an audible alarm provide the following - in addition to the devices required for the door type.

**APPENDIX B**  
**TYPICAL DEVICE**  
**CONNECTION**  
**DETAILS**

**PANEL CONNECTIONS**  
Typical For Each Door

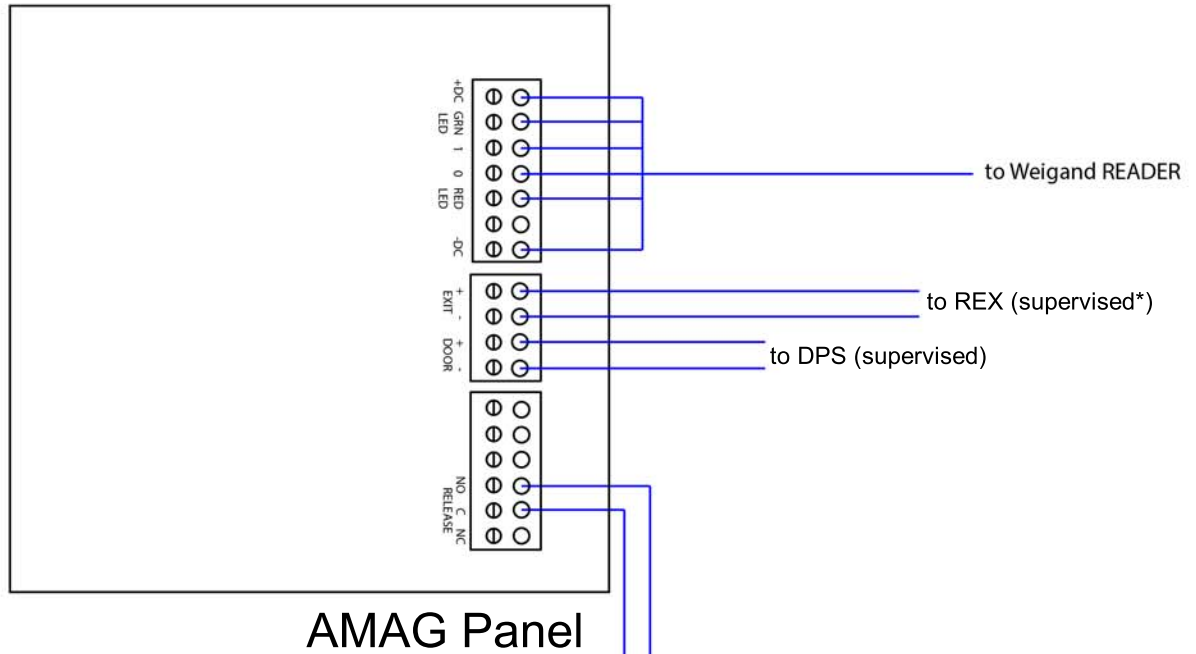

Insulating Barrier

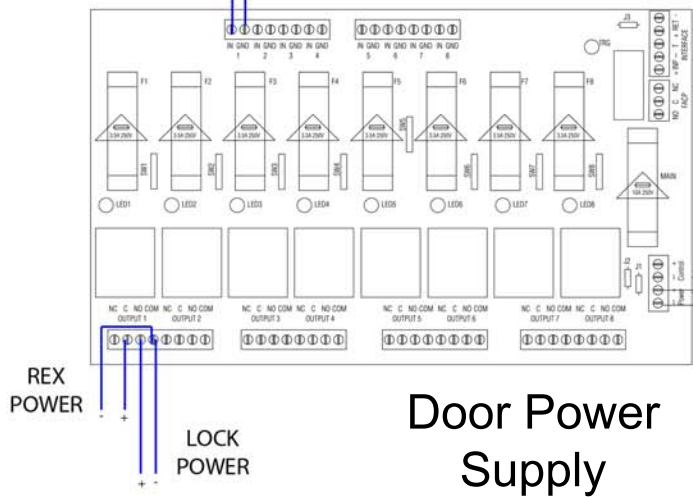

\* For REX switches integral to the door hardware locate the supervisory resistor behind the power transfer device on the door side.

**PANEL CONNECTIONS**  
Typical Monitored Door

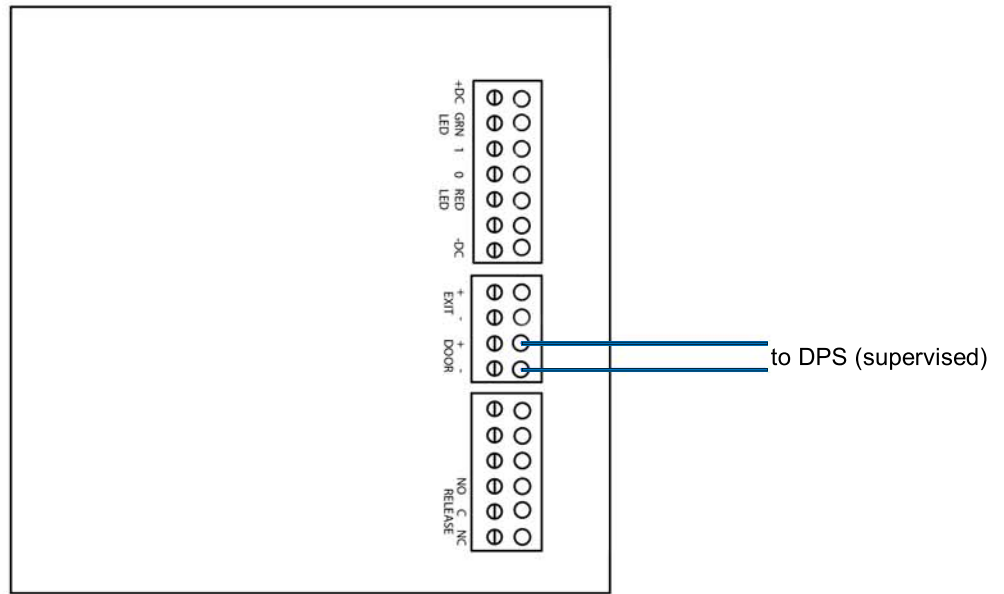

**AMAG Panel**

**PANEL CONNECTIONS**  
Typical REX Motion

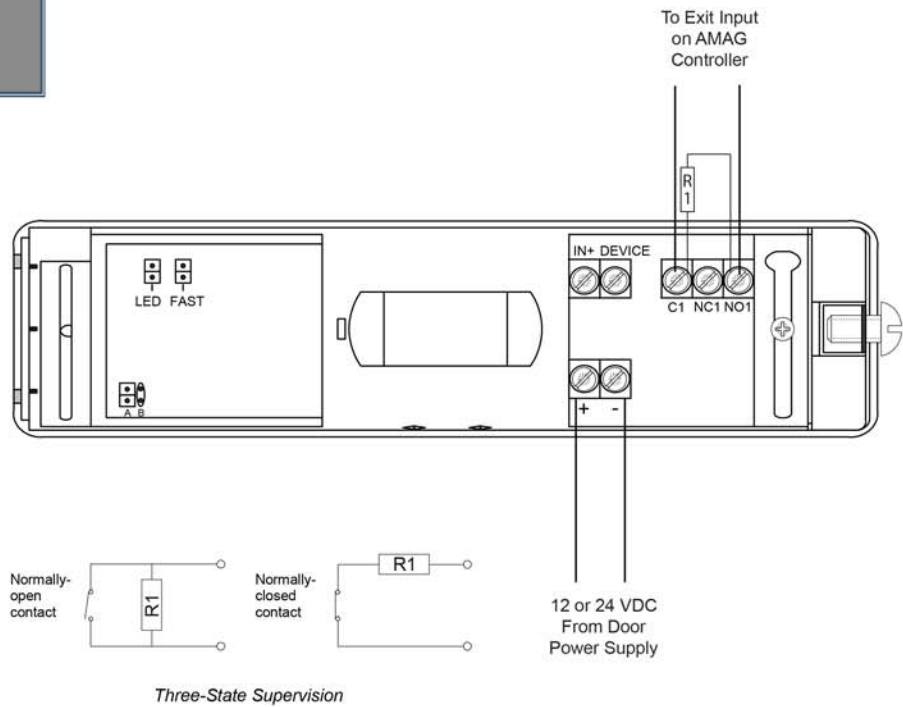

**Request-To-Exit (REX) Motion Detector**

**PANEL CONNECTIONS**  
**Typical Motion Sensor**

**INSTALLATION NOTES:**

Mount box 7' - 10' AFF to center. Align box vertically and horizontally with other nearby visual elements.

Provide gimble mount bracket to increase the aiming range of the device.

Provide 6C / 22AWG, plenum rated, cable from each motion detector to the control panel.

Provide bushing for any conduit end without a connector.

Firestop any penetrations made through rated assemblies.

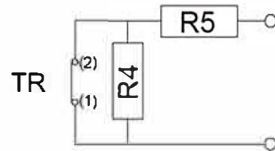
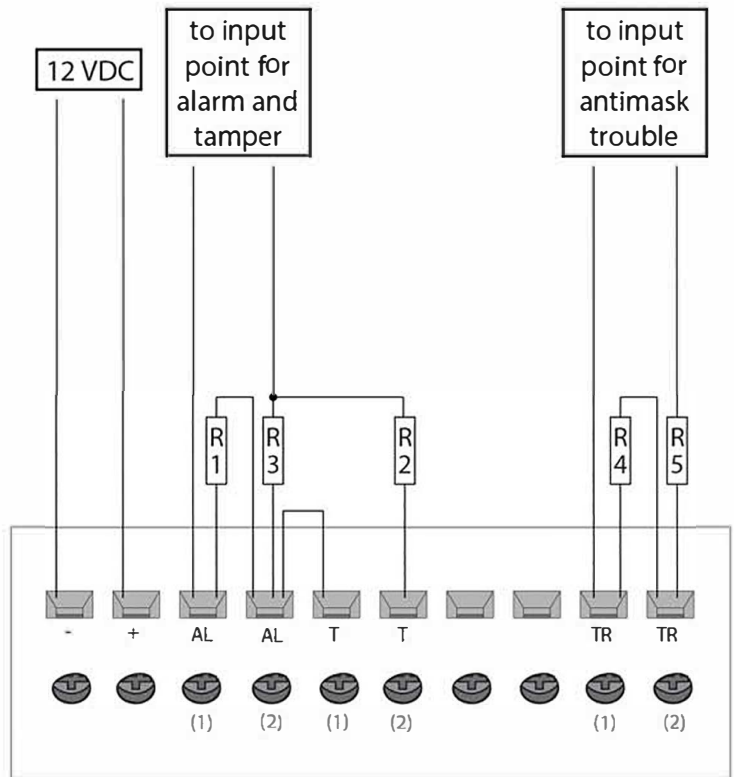

**Four-State Supervision**

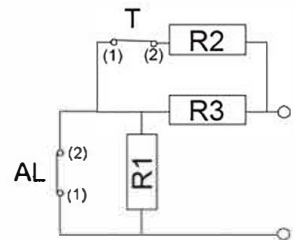

**Six-State Supervision**

Tamper and anit-mask trouble shall report 24/7 and be unaffected by disarming of the area.

# APPENDIX C

## CONTACTS

**OWNER**

**Anthony Jackson**

Executive Director, Emergency Management/ Fire Safety and Security

Jerry Sue Thornton Center Rm 175

(216) 987-3012

[Anthony.Jackson@tri-c.edu](mailto:Anthony.Jackson@tri-c.edu)

**Tri-C Police Dispatch**

Phone (216) 987-4325

# APPENDIX D

## LABELING





## TRI-C- CPSS LABELING GUIDE

DEVICE ABBREVIATION		FORMAT				
SECURITY		BLDG	DEVICE	FLOOR	LOCATION 1	LOCATION 2
CR	Card Reader Door	See List	See List	FLR-1, FLR-2, FLR-3, FLR-B, FLR-L (Lower Level), FLR-G	Room xyz, (Main, North, South, etc) Lobby, Hall Adj to Rm XYZ, etc.	For more than one device in room add compass direction. (AC) designates the device is above the ceiling.
DC	Monitored Door (Door Contact)					
GB	Glass Break Detector					
PB	Duress (Panic) Button					
MD	Motion Detector					
C#1-#2	Camera (#1 - floor, #2 = unique device #)	EXAMPLES				
		EHCT MD FLR-1 Room 102				
		MSS DC FLR-5 Main Lobby				
		WAATC DD FLR-1 Hall Adj To Main Office				
		C1-1 (First Camera on first floor)				
FIRE						
DD	Duct (Smoke) Detector					
PS	Pull Station					
SD	Smoke Detector					
TS	Sprinkler Tamper Switch (Valve Closed)					
WF	Sprinkler Water Flow					

<b>BUILDING ABBREVIATIONS</b>		
<b>CAMPUS</b>	<b>BUILDING</b>	<b>ABBREVIATION</b>
Eastern	Education Center	EEC
Eastern	Health Career Technology	EHCT
Eastern	Liberal Arts Building	ELA
Eastern	Student Services Building	ESS
Metro	Advanced Technology Training Center	ATTC
Metro	Arts and Music Auditorium	MAM
Metro	Building and Grounds	MBG
Metro	Business and Administration	MBA
Metro	Campus Center	MCC
Metro	Tommy Li Puma Center for Creative Arts	MCCA
Metro	Health Careers and Sciences	MHCS
Metro	Liberal Arts	MLA
Metro	Media Center	MMC
Metro	Recreation Center	MRC
Metro	Student Services	MSS
Metro	Technology Learning Center	MTLC
Metro	Theatre Arts	MTA
Metro	Unified Technologies Center	UTC
West	Advanced Automobile Technology Center	WAATC
West	Business and Technology	WBT
West	Fire Center	WFC
West	Health Technologies Center	WHTC
West	Liberal Arts	WLA
West	Recreation Center	WRC
West	Student Services	WSS
West	Technology Learning Center	WTLC
West	Theatre Arts	WTA
Satellite	Brunswick University Center	BUC
Satellite	Corporate College® West	CCW
Satellite	Corporate College® East	CCE
Satellite	District Administrative Services	DISTRICT
Satellite	Hospitality Management Center at Public Square	HMC
Satellite	Jerry Sue Thornton Center	JSTC
Satellite	Westshore Campus	WSH

This document has been prepared by Gryffon LLC.  
[www.gryffon.pro](http://www.gryffon.pro)



# ACCESS CONTROL DOOR W/ AUTOMATIC OPERATOR

## Sequence of Operation

ACTION		DOOR HARDWARE		DOOR OPERATOR			SWITCHES AND SENSORS			COMMENTS/NOTES
		LATCH	LOCK	DOOR OPEN / CLOSED	PUSH PLATE - EXTERIOR	PUSH PLATE - INTERIOR	READER	REQUEST TO EXIT (RTE)	DOOR POSITION SWITCH (DPS)	
Locked Normal - No Action		LATCHED	LOCKED	CLOSED	DISABLED	ENABLED	RED (STEADY)	NORMAL	CLOSED	
INT	Interior Push Plate Activated	UNLATCHED*	UNLOCKED*	OPEN**	DISABLED	ACTIVE	GREEN (STEADY)*	ACTIVE	OPEN	
INT	Exit manually via panic bar or door lever	UNLATCHED (MANUAL)	LOCKED	OPEN (MANUAL)	DISABLED	ENABLED	GREEN (STEADY)*	ACTIVE	OPEN	
EXT	Exterior Push Plate Activated	LATCHED	LOCKED	CLOSED	DISABLED	ENABLED	RED (STEADY)	NORMAL	CLOSED	Door Operator should not activate or attempt to open the door.
EXT	Present Card (Access Denied)	LATCHED	LOCKED	CLOSED	DISABLED	ENABLED	RED (FLASHING)	NORMAL	CLOSED	
EXT	Present Card (Access Granted)	UNLATCHED*	UNLOCKED*	CLOSED	ENABLED*	ENABLED	GREEN (STEADY)*	NORMAL	CLOSED	Door may be pulled open manually or the exterior push plate may be used*
EXT	Door opened with a key or forced open	-	-	-	-	-	-	-	OPEN	Door Forced Alarm Activated
-	Door propped or fails to close 90 seconds after a valid opening.	-	-	-	-	-	-	-	OPEN	Door Propped Alarm Activated.
Unlocked Normal - No Action		UNLATCHED ***	UNLOCKED	CLOSED	ENABLED	ENABLED	GREEN (STEADY)	NORMAL	CLOSED	
-	Interior or Exterior Push Plate Activated	UNLATCHED	UNLOCKED	OPEN**	ENABLED	ENABLED	GREEN (STEADY)	ACTIVE	OPEN	
-	Exit or enter manually via panic bar, door levers, or pull handles	UNLATCHED	UNLOCKED	OPEN (MANUAL)	ENABLED	ENABLED	GREEN (STEADY)	-	OPEN	

\* For 15 seconds (Typical)

\*\* Temporarily open for operator cycle

\*\*\* May need to be latched in high wind areas.

A dash (-) indicates N/A



## SECURITY SURVEILLANCE SYSTEM - CAMERAS

Security Commissioning Pre-Functional Checklist Rev 12/17/2020

IP ADDRESS# \_\_\_\_\_

LOCATION \_\_\_\_\_

<i>(Use 1 sheet per camera)</i>		Contractor Verification			Commissioning Agent Verification			
ITEM #	ITEM	Date	Y, N, or NA	Initials	Date	Status	Initials	COMMENTS/NOTES
CAM-ADJ- 1	Has camera direction and field of view been adjusted in coordination with the Owner?							
CAM-ADJ- 2	Has final focus of camera been completed maximizing the DOF for the area of interest?							
CAM-ADJ- 3	Are all horizons level and ceiling and wall views minimized?							
CAM-ADJ- 4	Does exterior camera change from day to night view successfully?							
CAM-ADJ- 5	Has the white balance been adjusted for the scene to provide a common tone across all cameras?							
CAM-ADJ- 6	Has the AGC or HDR settings been adjusted as necessary for all times of day based on historical footage?							
CAM-GEN- 1	Does installed equipment match the approved submittal / shop drawing?							
CAM-GEN- 2	Is device securely mounted with a backbox on wall or backbox and supports on suspended ceilings?							
CAM-GEN- 3	Has the device and its wiring been installed in accordance with manufacturers published instructions?							
CAM-GEN- 4	Device is not visibly damaged?							
CAM-GEN- 5	Workmanship clean and neat? Cleaning of device glass and optics is completed?							
CAM-GEN- 6	Is normal recording quality acceptable to Owner?							
CAM-GEN- 7	Is low light recording quality acceptable to Owner?							
CAM-LAB- 1	Is device labeled with a identification number for general and drawing reference?							



## SECURITY SURVEILLANCE SYSTEM - CAMERAS

Security Commissioning Pre-Functional Checklist Rev 12/17/2020

IP ADDRESS# \_\_\_\_\_

LOCATION \_\_\_\_\_

(Use 1 sheet per camera)		Contractor Verification			Commissioning Agent Verification			
ITEM #	ITEM	Date	Y, N, or NA	Initials	Date	Status	Initials	COMMENTS/NOTES
CAM-LAB-2	Are network cables labeled / tagged at the switch to identify them as "do not disturb?"							
CAM-PROG- 1	Has device programming / config been completed in coordination with the Owner?							
CAM-PROG- 2	Have presets, tours, window blanking or other features been configured in coordination with the Owner?							
CAM-PROG- 3	Has the camera been configured for time sync from an NTP server?							
CAM-PROG- 4	Have motion rates been adjusted based on scene content, motion direction, and likely speed of activity?							
CAM-PROG- 5	Has Motion detection / other analytics been programmed?							
CAM-PROG- 6	Has Motion detection / other analytic programming been readjusted to minimize false triggers?							
CAM-PROG- 7	Is an alarm configured if there is a loss of video or communication?							
CAM-PROG- 8	Has camera firmware been updated to most recent version supported by manufacturer of recording server?							